

BIXOLON

User's Manual

XM7-30 Series

MOBILE PRINTER

Ver. 1.00



<http://www.bixolon.com>

Table of Contents

Copyright	4
WARNING & CAUTION	7
Manual Introduction	10
Product Introduction.....	11
1. Preparation.....	12
1-1 Components	12
1-2 Front Part Names	13
1-3 Rear Part Names	13
1-4 LCD Menu Names.....	14
1-4-1 Top icon	14
1-4-2 Main menu icon	15
2. Installation & Connection	17
2-1 Battery Installation.....	17
2-2 Battery Charging	18
2-2-1 Using AC/DC Adapter	18
2-2-2 Using Single Battery Charger (Optional)	19
2-2-3 Using Quad Battery Charger (Optional)	20
2-3 Media Installation.....	22
2-4 Bluetooth & Wireless LAN Connection	24
2-5 Interface Cable Connection.....	25
2-6 Fixed Interface Cable Connection	26
3. Use.....	27
3-1 Using Peeler	27
3-2 Using Belt Strap.....	28
3-3 Using Shoulder Strap (Optional)	29
3-4 Using Fan-Fold Media	30
3-4-1 Media Width 3-inch.....	30
3-4-2 Media Width 3-inch FAN FOLD	30
3-4-3 Media Width 28~76 mm (1.10~2.99 inch)	30
3-4-4 Separate the Fan-Fold Cap.....	31
3-5 Using Control Button	32
3-5-1 Power Button	32
3-5-2 Media Feed Button	32
3-5-3 Menu Move Button.....	32
3-5-4 Menu Select Button	32

4. Self-Test..... 33
 4-1 Self-Test Instructions33
 4-2 Self-Test Sample 34

5. Cleaning 36

6. Appendix..... 37
 6-1 Printer Specifications37

Copyright

© BIXOLON Co., Ltd. All rights reserved.

This user manual and all property of the product are protected under copyright law. It is strictly prohibited to copy, store, and transmit the whole or any part of the manual and any property of the product without the prior written approval of BIXOLON Co., Ltd. The information contained herein is designed only for use with this BIXOLON product. BIXOLON is not responsible for any direct or indirect damages, arising from or related to use of this information.

- The BIXOLON logo is the registered trademark of BIXOLON Co., Ltd.
- All other brand or product names are trademarks of their respective companies or organizations.

BIXOLON maintains ongoing efforts to enhance and upgrade the functions and quality of all our products.

In the following, product specifications and/or user manual content may be changed without prior notice.

Caution

Electronics, such as printers, are prone to damage by static electricity. Therefore, to protect the printer from static electricity, be sure to turn off the printer before connecting or disconnecting the cable to the rear of the printer. If the printer is damaged by static electricity, contact your local dealer.

Compliance information

This device complies with Part 15 of the FCC Rules. Operation is subject to the following two conditions: (1) This device may not cause harmful interference, and (2) This device must accept any interference received, including interference that may cause undesired operation.

This equipment has been tested and found to comply with the limits for a Class A digital device pursuant to Part 15 of the FCC Rules. These limits are designed to provide reasonable protection against harmful interference when the equipment is operated in a commercial environment. This equipment generates uses, and can radiate radio frequency energy and, if not installed and used in accordance with the instruction manual, may cause harmful interference to radio communications. Operation of this equipment in a residential area is likely to cause harmful interference in which case the user will be required to correct the interference at his own expense.

Caution: Exposure to Radio Frequency Radiation.

To comply with FCC RF exposure compliance requirements, a separation distance of at least 20 cm must be maintained between the antenna of this device and all persons.

Caution: Any Changes or modifications not expressly approved by the manufacturer could void the user's authority to operate the equipment.

Class A Digital Device: Wired Device

This Apparatus complies with class "A" limits for radio interference as specified in the Canadian department of communications radio interference regulations.

This Class A digital apparatus complies with Canadian ICES-003.

Informations de conformité

Appareil numérique de classe A: appareil filaire

Get appareil est conforme aux normes class "A" d'interference radio tel que specifier par ministre canadien des communications dans les reglements d'interference radio.

Cet appareil numérique de la classe A est conform à la norme NMB-003 du Canada.

Waste Electrical and Electric Equipment (WEEE)



This marking shown on the product or its literature, indicates that it should not be disposed with other household wastes at the end of its working life. To prevent possible harm to the environment or human health from uncontrolled waste disposal, please separate this from other types of wastes and recycle it responsibly to promote the sustainable reuse of material resources. Household users should contact either the retailer where they purchased this product, or their local government office, for details of where and how they can take this item for environmentally safe recycling. Business users should contact their supplier and check the terms and conditions of the purchase contract. This product should not be mixed with other commercial wastes for disposal.



WARNING & CAUTION

It describes death, physical injuries, serious financial losses, and damage to data etc. that can be caused to the user.

Do not connect multiple products to a single or faulty power outlet. Use only grounded power outlets that meet the industry standard. **Noncompliance may cause electric shock or fire.**



Only use authentic products from BIXOLON. The company will not provide post-sale support for damaged or other quality issues that any fake (or refurbished) products may incur.

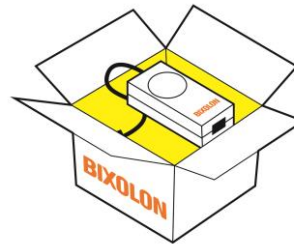

Do not excessively bend or strain the power cord. Securely push the power cord all the way into the power outlet lest it remain loose. Make sure to hold the cord tight when separating it from the power outlet. Do not remove the power cord while the product is in use. **Noncompliance may cause electric shock or fire.**

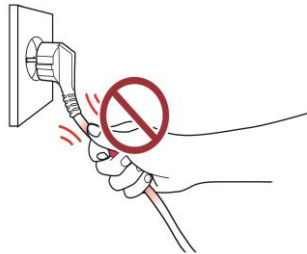

Keep small accessories or other packaging materials away from young children. Beware: choking hazard. **Mishandling the product may incur injuries which may require seeking urgent medical attention.**



Keep excessive liquids away from the power cord and outlet. If matter is smeared onto the power cords, wipe with a dry cloth. **Noncompliance may cause electric shock or fire.**

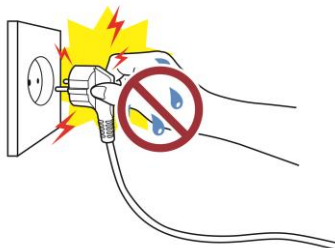

Do not allow the product to be damaged by heavy objects. **Noncompliance may cause electric shock or fire.**

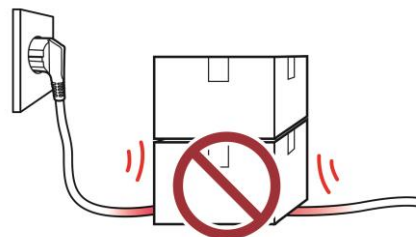

If the product emits a strange sound, burning smell, or smoke, turn off the power immediately and unplug the power cord. If the product is dropped or its exterior is damaged, turn off the power immediately and unplug the power cord. Do not subject the product to shock. **It may start a fire. It may damage the product.**

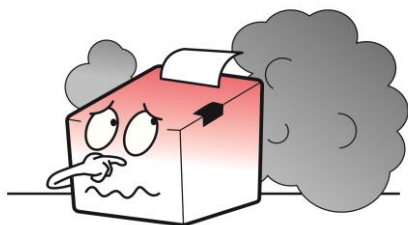

Install the product in a well-ventilated area by keeping it a certain distance from the wall. The product installed in certain places such as where a lot of fine dust is generated, where the temperature is too high or too low, where there is a lot of moisture or water, and at airports or stations that are used continuously for a long time may suffer serious quality problems due to the influence of the surrounding environment. **An increase in internal temperature may start a fire. Be sure to contact the place of purchase before installing the product.**

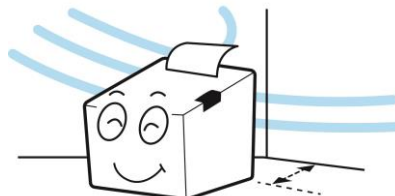

Install the product in a fixed place preventing it from tipping over. When moving the product, turn off the power and disconnect all connected cables, including the power cord. **It may damage the product.**



Never independently disassemble, repair, or modify the product as the warranty will become invalid. **When repair is necessary, contact the original place of purchase.**



Do not let any foreign substances enter the product. Do not place heavy objects, liquids, or metals on the product. **This could cause damage to the product or a fire.**



If there is a problem with the product, please contact the original place of purchase or through BIXOLON website's product repair page (<http://www.bixolon.com>).

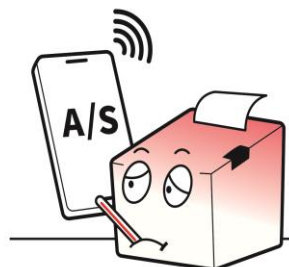



WARNING & CAUTION

It's to use the battery properly and prevent danger or physical damage, so please keep it.

Do not subject the battery to strong impact or throw it. Do not disassemble or modify the battery. Do not allow battery leakage to come into contact with your eyes or skin. Keep the battery out of the reach of children and make sure that children do not swallow it. **Otherwise, it can cause the deterioration of battery performance and lifespan, overheating, rupture, or ignition. If it comes in contact with skin or is swallowed, consult a doctor immediately.**



If the battery is not to be used for a long time, disconnect it from the device being used and keep it in a dry place. Even if it is not used for a long time, charge it at least once every 6 months while in storage. Do not place the battery in places exposed to high temperatures (direct sunlight, inside a car, etc.) or where static electricity is generated (near home appliances, etc.), or near heat generating devices (heating device, etc.). Do not put the battery in a fire, microwave, or high pressure (pressure cooker, etc.). Make sure that the product does not come in contact with metals (coins, necklaces, etc.) or liquids (water, salt water, etc.). Stop using the battery if it develops an odor or any other abnormalities such as heat, discoloration, deformation, or leakage while using, storing, or charging the battery.



Do not be confused about the (+) and (-) terminals of the battery. Do not let metal contact the (+) and (-) terminals of the battery. If the (+) and (-) terminals of the battery are smeared with extraneous matter, wipe them clean with a piece of dry cloth. **Otherwise, it can cause deterioration of battery performance and lifespan, overheating, rupture, or ignition.**



The battery should only be charged using the adapter or charger provided by Bixelon, and if charging fails after the specified charging time (6 hours), stop charging. Do not charge the product longer than the charging time specified in this manual. **Otherwise, it can cause deterioration of battery performance and lifespan, overheating, rupture, or ignition.**



Store and use the battery within the proper operating temperature range.

- Charging: 0 - 40°C (32 - 104°F)
- In use: -15 - 50°C (5 - 122°F)
- Long-term storage (more than 30 days): 15 - 40°C (5 - 104°F)

Otherwise, it can cause deterioration of battery performance and lifespan, overheating, rupture, or ignition.

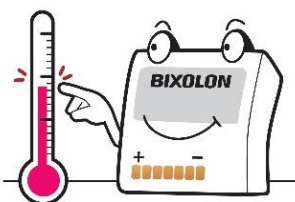

Be sure to turn off the power of the device the battery serves after use. When disposing of the battery, completely discharge the battery and insulate the terminals with tape, etc. **Dispose of it in a designated place according to the relevant laws and regulations of the country.**

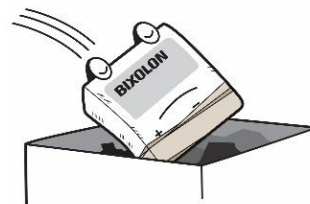

Manual Introduction

The manual provides basic information on the printer and describes how to install, use, and inspect it. To ensure your safety and prevent damage to your property, make sure you read the manual thoroughly before using the machine.

Manual Symbol Introduction



**Precaution &
Warning**

It describes death, physical injuries, serious financial losses, and damage to data etc. that can be caused to the user.



Note

It provides additional information on the function and performance of the product.





Product Introduction

The XM7-30 is a 3-inch thermal mobile label printer which simultaneously connects with Bluetooth and WLAN. Ideal for smart mobility labelling due to its compact, lightweight design with an easy-to-open peeler and LCD.

The main features of the printer are as follows

1. 3-inch Mobile Label Printer
2. Printing speed: Maximum 127 mm/s (5ips)
3. Compact and light design: 119 x 180 x 79 mm (4.69 × 7.09 × 3.12 inch) (W x D x H)
4. Peeler
5. Media holder: media width 50 ~ 80 mm
6. Wireless connectivity: Bluetooth V5.2(MFi certified), Wireless LAN 802.11 a/b/g/n

Product Symbol Introduction

	AC (Alternation Current)
	DC (Direct Current)
	USB
	NFC

1. Preparation

1-1 Components



- If any items are missing, contact the place of purchase.
- The image may differ from the actual product.

※ Basic items



XM7-30

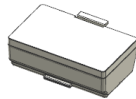

Smart Battery



AC/DC Adapter



Power Cord



Belt Strap

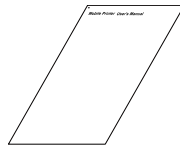

Printer
Installation Guide

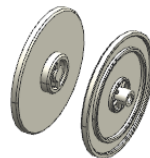

Media Disks
(for 12 mm (0.47 inch)
inner diameter)

※ Optional items

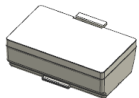

Battery

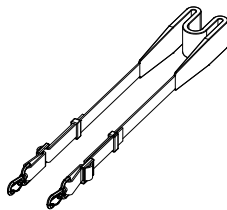

Shoulder Strap



Vehicle Adapter

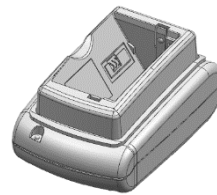

Single Battery
Charger

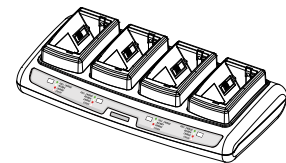

Quad Battery
Charger



Serial
Interface Cable
(for Serial/USB 14pin port)



USB
Interface Cable
(for Serial/USB 14pin port)



Fixed Serial
Interface Cable
(for Serial/USB 14pin port)



Fixed USB
Interface Cable
(for Serial/USB 14pin port)

1-2 Front Part Names

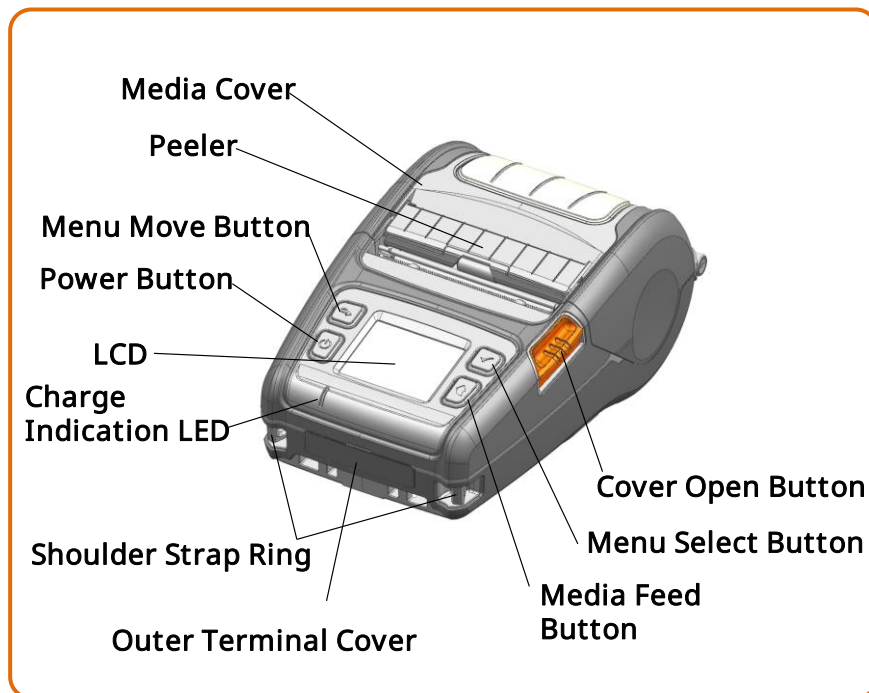

1-3 Rear Part Names

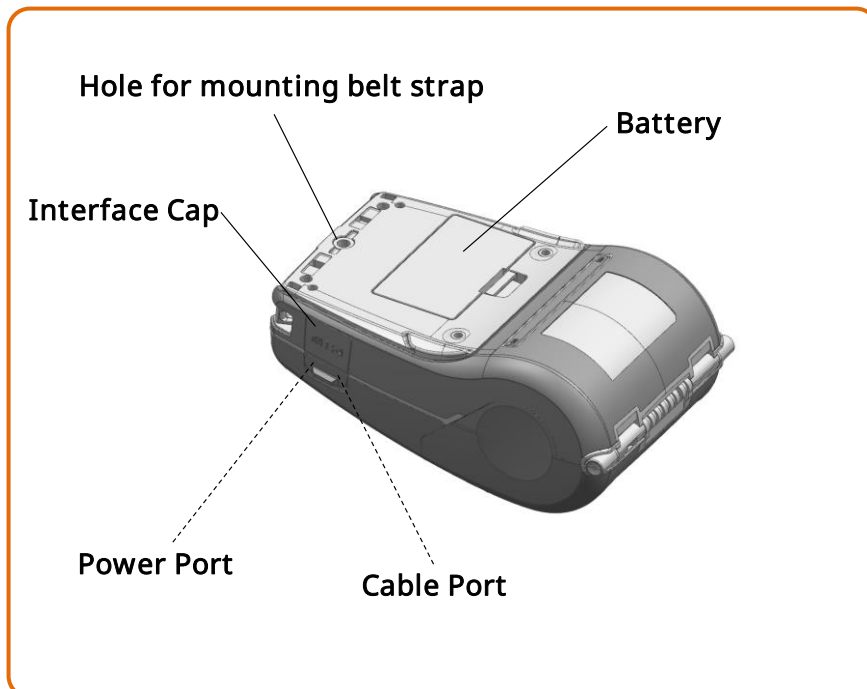

1-4 LCD Menu Names



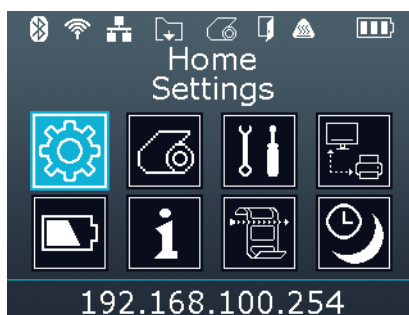

- You can check printer status and setting information through LCD.





1-4-1 Top icon

Icon	Description
	Bluetooth is enabled but not connected to the host device
	Bluetooth is enabled and connected to the host device
	Display signal strength of wireless LAN
	Can not searching the registered AP
	Authentication failed
	LAN is enabled and connected
	Receiving data, printing or media feed
	Media empty
	Media cover open
	TPH overheating
	Battery status

1-4-2 Main menu icon

Icon	Description
	<p>Check / set the status of whole printer</p> <ol style="list-style-type: none"> 1) Interface 2) Media 3) Sensor 4) Powersave 5) Language
	<p>Media settings</p> <ol style="list-style-type: none"> 1) Density 2) Position <ul style="list-style-type: none"> - Tear off - Print - Direction
	<p>Tools</p> <ol style="list-style-type: none"> 1) Hex dump 2) Print printer config → Self test 3) Print test pattern 4) Printer factory reset
	<p>Check / set the status of the interface</p> <ol style="list-style-type: none"> 1) Bluetooth <ul style="list-style-type: none"> - On/Off - SSP (Secure Simple Pairing) / PIN code mode setting - BLE / Classic mode setting - Information (Name, MAC address) 2) Wireless LAN <ul style="list-style-type: none"> - On/Off - Information (SSID, Mode, Encryption, IP, Port, MAC address, Inactivity time) - Smart connection (easy connection to AP by linking with smart connection APP) - Factory reset 3) LAN <ul style="list-style-type: none"> - On/Off - Information (IP, Port, MAC address, Inactivity time)
	<p>Check the battery status</p>

	<p>Check printer information</p> <ol style="list-style-type: none"> 1) Version <ul style="list-style-type: none"> - Printer, WLAN, Bluetooth 2) Bluetooth 3) WLAN 4) LAN 5) Battery 6) Repair
	<p>Sensor settings</p> <ol style="list-style-type: none"> 1) Media type <ul style="list-style-type: none"> - Auto detection / Rear black mark / Front black mark / Gap - Continuous 2) Peeler <ul style="list-style-type: none"> - On/Off - Sensor sensitivity adjustment 3) RFID <ul style="list-style-type: none"> - Setting (Transponder position, Power, Number of retry, Number of label) - Calibration - Information (Band, Valid count, Void count)
	<p>Set Backlight, Sleep and Power off Time</p> <ol style="list-style-type: none"> 1) Backlight brightness 2) Backlight off time 3) Sleep time 4) Power off time

2. Installation & Connection

2-1 Battery Installation



- 1) Insert the battery in the bottom of the printer, and ensure that you align the battery hook properly.
- 2) Push the battery into the slot until you hear it snap in place.



Since the battery is partially charged at the time of purchase, charge the battery prior to product use.

Use the AC/DC adapter or the optional Single/Quad battery charger.



- **Be sure to turn off the printer before connecting the power cord to the printer. This can cause serious electrical damage and bodily injury.**
- **Do not operate the printer and power supply in a humid environment. This can cause serious electrical damage and bodily injury.**

2-2 Battery Charging

2-2-1 Using AC/DC Adapter

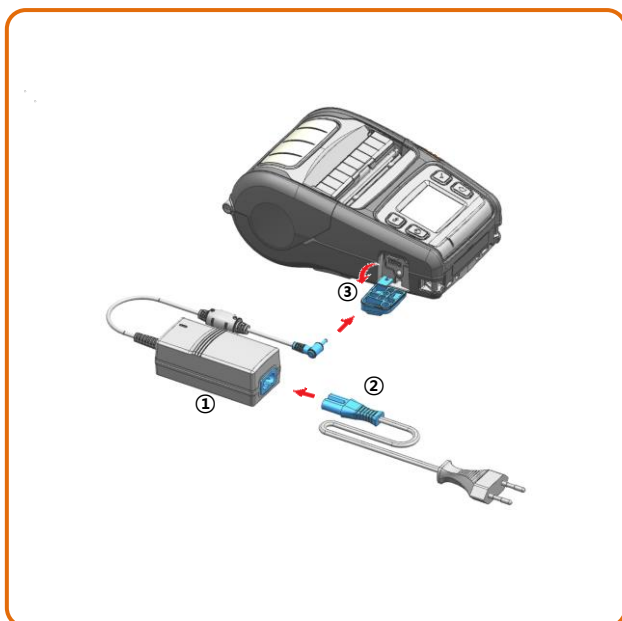

- 1) Turn off the printer power.
- 2) Connect the power cord ② to the AC/DC adapter ① and then connect AC power.
- 3) Open the external interface cap in the direction of ③.
- 4) Connect the AC/DC adapter to the power port.

LED	Charge Status	Charge Time
Red LED On	Charging	Within 3 hours
Green LED On	Fully Charged	
Red LED Blinking	Error Replace or Reinstall Battery	



- Charge the battery only after disconnecting the power to your device.
- Use only genuine products supplied by Bixolon. Otherwise, the product may malfunction or there is a risk of personal injury.

2-2-2 Using Single Battery Charger (Optional)

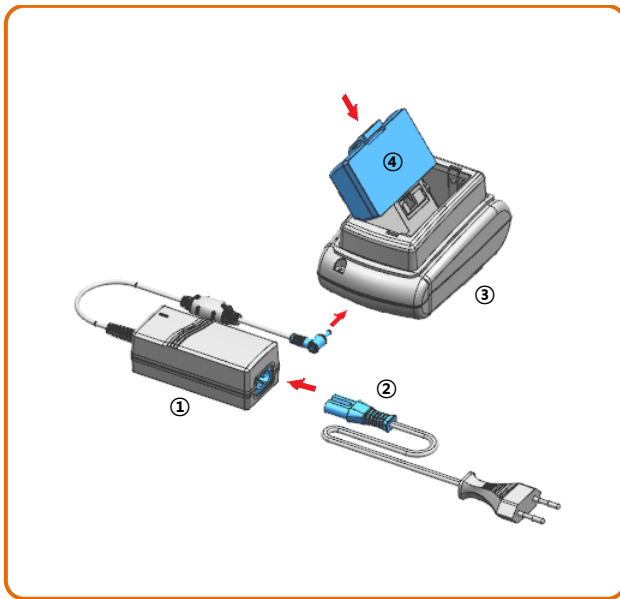

- 1) Connect the power cord ② to the battery charger ①.
- 2) Connect the battery charger ① to the power port of the cradle ③.
- 3) Plug the power cord ② into an AC power.
- 4) Insert the battery ④ into the cradle ③ a snapping sound is heard.



You must use the battery charger provided by BIXOLON to use the singles battery charger. (AC/DC adapter is not available)



- Charge the battery only after disconnecting the power to your device.
- Use only genuine products supplied by Bixelon. Otherwise, the product may malfunction or there is a risk of personal injury.

2-2-3 Using Quad Battery Charger (Optional)

2-2-3-1 Connecting the cables

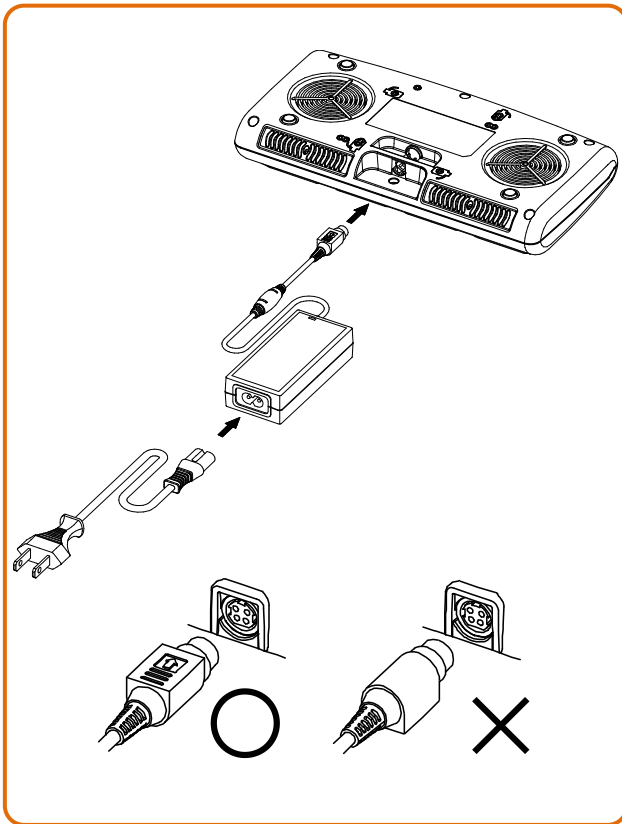

- 1) Connect the power cord to the Adapter, and connect the Adapter to the power port of the quad battery charger.
- 2) Plug the power cord into a AC power. Input power is 100 ~ 240 VAC, 50/60 Hz, 1.0 A.
- 3) When the power is supplied, the yellow, green and red LEDs are on for three seconds and do the self-test.



Use only designated AC/DC Adapter. (12 VDC, 3 A)

2-2-3-2 Charging Battery

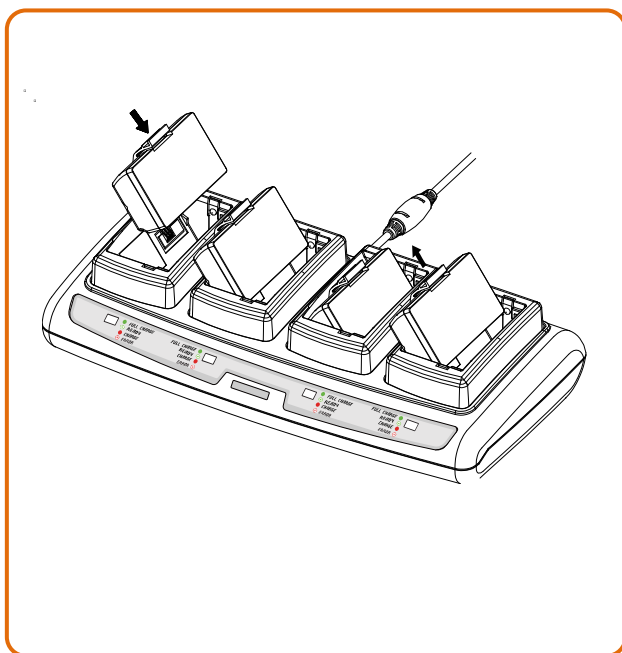

- 1) Insert the battery into the Quad charger as shown in the figure on the left.
- 2) Gently slide the battery until it reaches the bottom of the charger.
- 3) Charging starts as soon as the battery is completely inserted.
- 4) After charging, remove the battery from the Quad charger.

LED	Charge Status	Charge Time
Red LED On	Charging	Within 4 hours
Green LED Blinking	Over 80% Charged	
Green LED On	Fully Charged	
Red LED Blinking	Error Replace or Reinstall Battery	



- If the red lamp of the charger blinks, install the battery again.
- If the red lamp continues to blink despite several attempts (4 ~ 5 times) to install the battery, contact your local dealer.
- The charging time may vary depending on the type of the charger or ambient temperature.

2-3 Media Installation

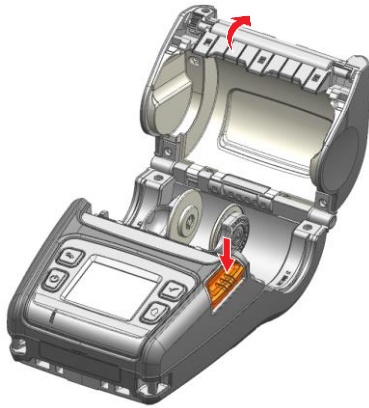

1) Press the Open button to open the media cover.

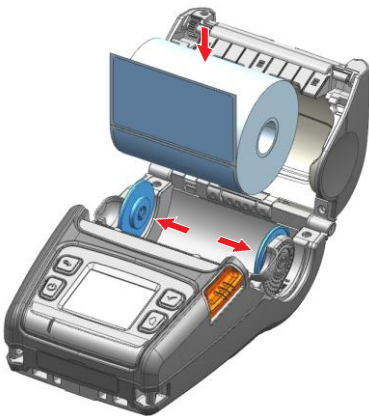

2) After keeping the media holder wide as shown, in the figure insert the media as shown.
(Remove the empty media core.)

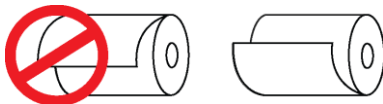

3) Check the orientation of the media when inserting it into the printer.

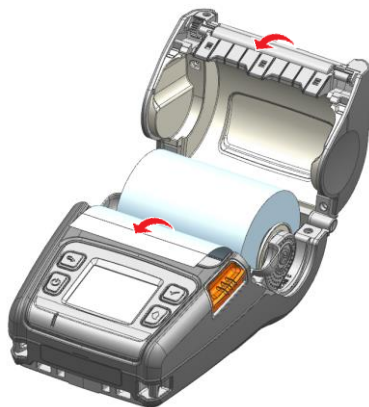

4) Pull out the media as shown and close the media cover.

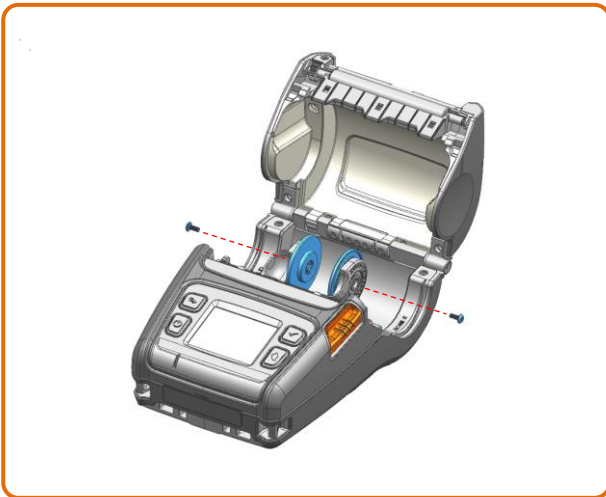

The specification of the media inner diameter of the standard media disks are 19 mm (0.75 inch).

If you are using media with a smaller inner diameter, remove the media disks as shown below and replace it with the supplied 12 mm (0.47 inch) media disks.



- When opening or closing the cover, be careful not to pinch your fingers.
- Do not open the print head levers while the printer is printing. The printer may be damaged.

2-4 Bluetooth & Wireless LAN Connection

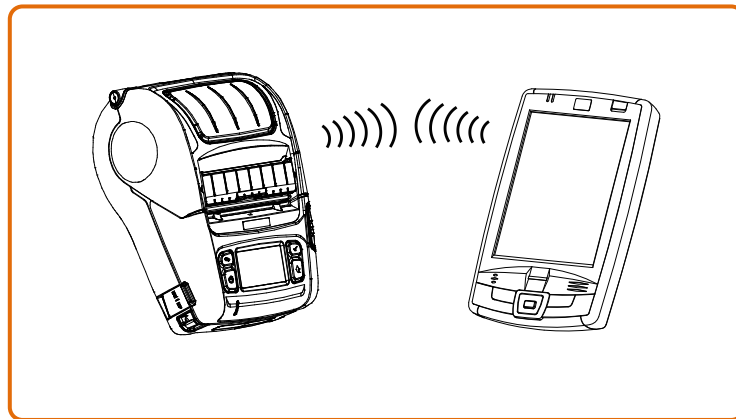

- 1) The printer can be connected to devices equipped with Bluetooth communication capacity (PDAs, PCs, etc.).
- 2) Use the Bluetooth connection function supported by the device to connect to the printer. The NFC tag built into the printer enables automatic pairing with devices.



- Tap your host device to logo on the side of the printer for NFC auto pairing. (📱)
- The device must support NFC Auto Pairing.
It may display a message that the device cannot be connected as NFC Auto Pairing is supported up to the Bluetooth pairing and the devices must be connected manually, but this is normal.

- 3) The printer can be connected to other stations, such as PDAs and PCs supporting wireless LAN communication in Ad-hoc mode, Soft AP mode and AP in Infrastructure mode.



- Refer to the Bluetooth & Wi-Fi Connection Manual for detailed information on its connection.
- You can check the bluetooth environment (authentication, encryption, connection mode) and the wireless LAN environment (IP, SSID, authentication, encryption) via the self-test page.

2-5 Interface Cable Connection

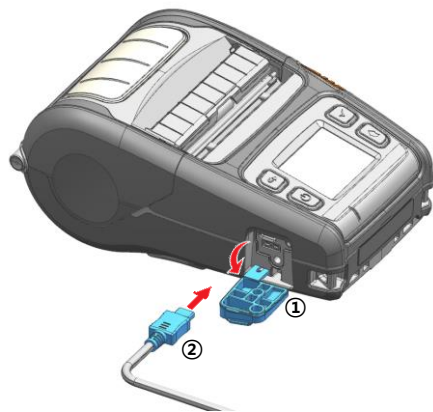

- 1) Open the Interface Cap ①.
- 2) Connect the external communication cable ② to the cable port of the printer.
- 3) Connect the interface cable to the USB port of the device (PDAs, PCs, etc.).

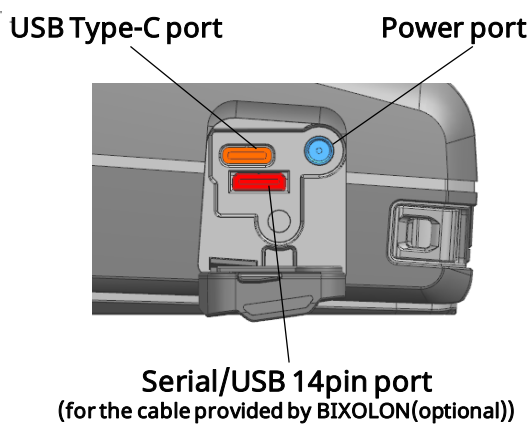

The interface cable that can be connected to the printer is Serial/USB cable provided by BIXOLON(optional) or USB Type-C cable supporting USB2.0.

2-6 Fixed Interface Cable Connection

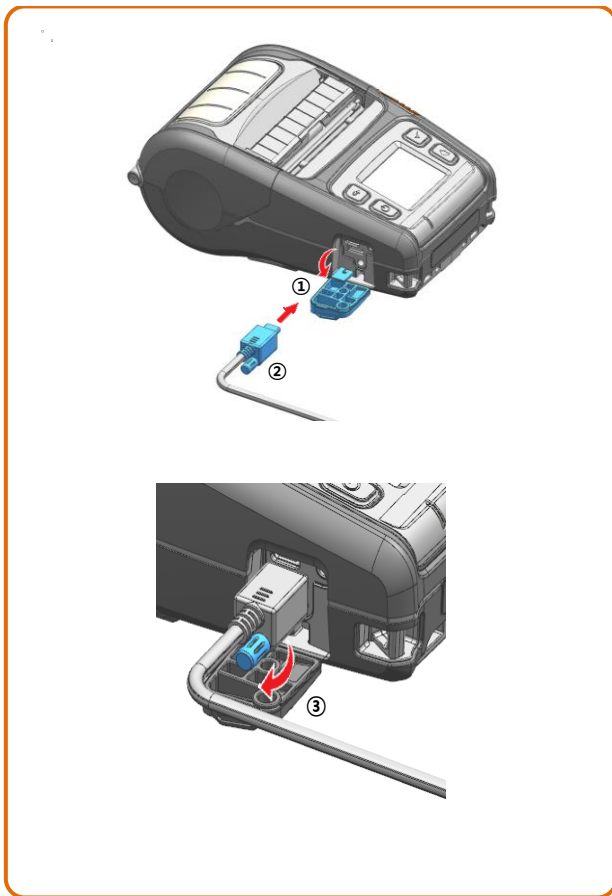

- 1) Open the Interface Cap ①.
- 2) Connect the external communication cable (optional) ② to the cable port of the printer.
- 3) Fix the interface cable by tightening the screw ③ as shown in the figure.
- 4) Connect the interface cable to the USB port of the device (PDAs, PCs, etc.).



The fixed interface cable that can be connected to the printer is Serial/USB cable provided by BIXOLON(optional).

3. Use

3-1 Using Peeler

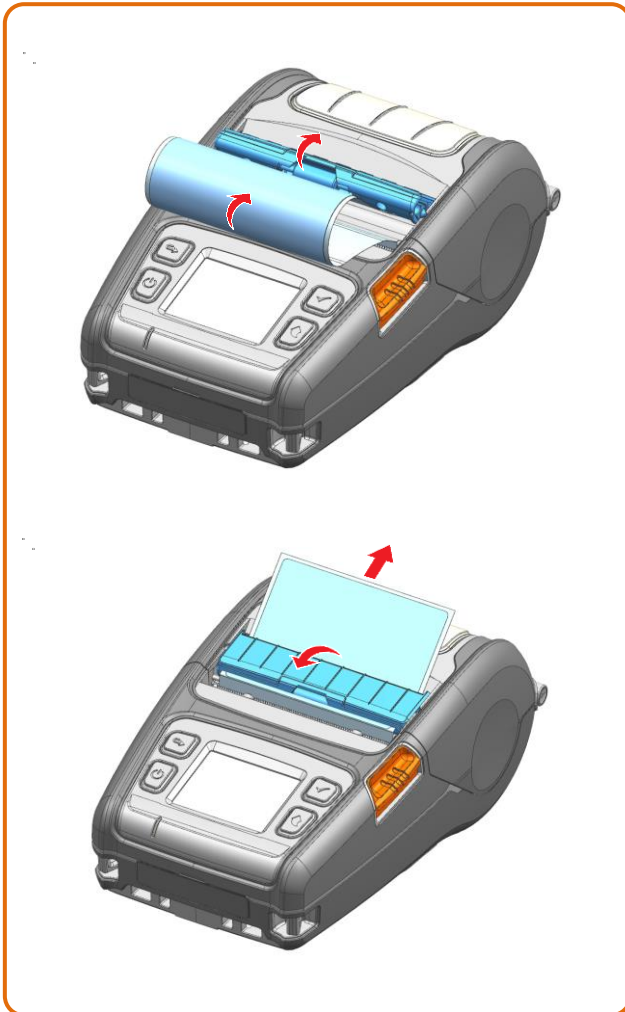

1) Insert the media after open the peeler as shown.

2) Pull out the media after close the peeler as shown.



Enable the peeler setting when using the peeler. Refer to "Sensor setting" of "1-4 LCD Menu" to enable peeler setting.



When opening or closing the cover, be careful not to pinch your fingers.

3-2 Using Belt Strap



1) Insert the belt strap screw into the belt strap hole.

2) Use a coin to tighten the belt strap screw as shown in the image.

3) Open the velcro of the belt strap and hook the belt strap to the belt.

4) Close the Velcro as shown in the image.

3-3 Using Shoulder Strap (Optional)



Please, insert hooks of the strap into each slot as shown in the picture.

3-4 Using Fan-Fold Media

3-4-1 Media Width 3-inch

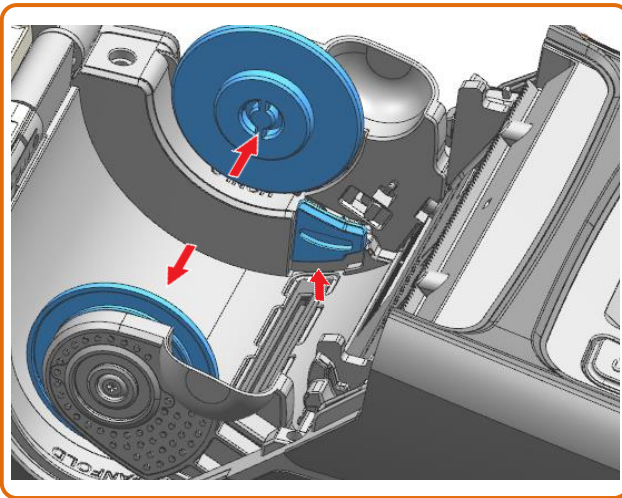

After keeping the media holder wide as shown in the figure, hold the media holder by lifting right guide holder as shown in the figure.

3-4-2 Media Width 3-inch FAN FOLD

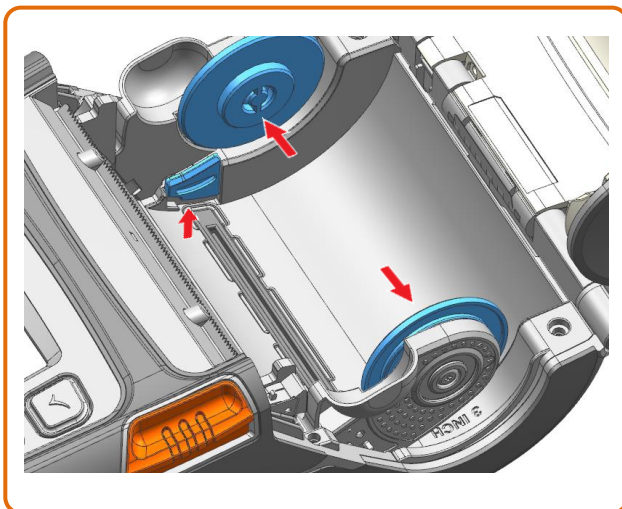

After keeping the media holder wide as shown in the figure, hold the media holder by lifting left guide holder as shown in the figure.

3-4-3 Media Width 28~76 mm (1.10~2.99 inch)

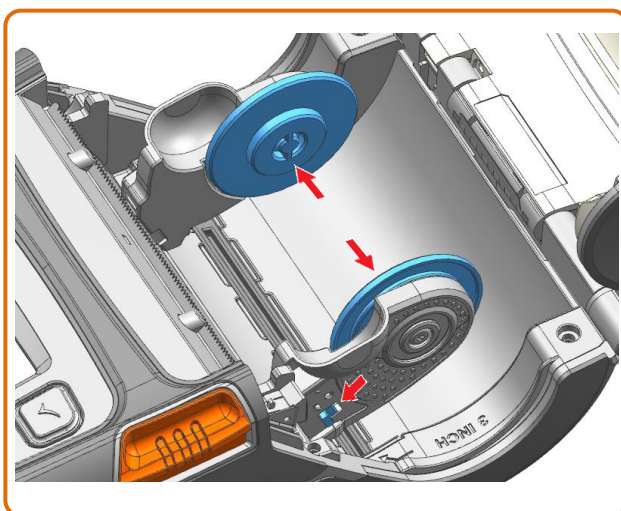

After keeping the media holder wide as shown in the figure, hold the media holder by using the latch as shown in the figure.

3-4-4 Separate the Fan-Fold Cap

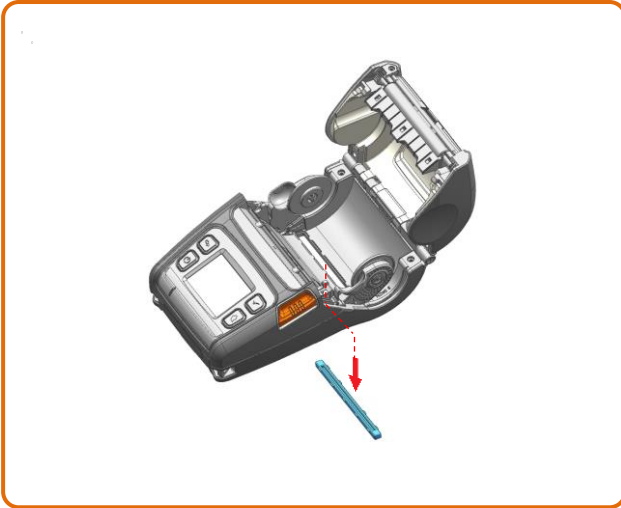

When using fan-fold media, remove the fan-fold cap beforehand.

3-5 Using Control Button



3-5-1 Power Button



This button is used to turn the printer on, off, to move to main menu or to operate the action.

- 1) When the printer is off, press this button for approximately 2 seconds to turn on the power.
- 2) When the printer is on, press this button for approximately 2 seconds to turn off the power.
- 3) Pressing this button while the LCD menu is being operated moves to the main menu or the action selected in the menu is operated.

3-5-2 Media Feed Button



This button is used to feed the media manually or return to the previous step.

- 1) Press and hold this button while the printer is booting to Print a self-test page.
- 2) Press this button in the standby mode to feed the media.
- 3) Press this button to return to the previous menu.

3-5-3 Menu Move Button



This button is used to move the LCD menu.

Press this button to move the LCD menu from the top left to the bottom right.

3-5-4 Menu Select Button



This button is used to select the LCD menu.

Press this button to select the LCD menu or save the selected settings to the printer.

4. Self-Test

Run the self-test to check the setting information when you are setting up the printer for the first time or if there is a problem.

If no issue is found with the printer after running the self-test, examine the other devices or peripherals and software. This function is independent of such other devices and software.

4-1 Self-Test Instructions

- 1) Turn the printer power on and go to the Tool > Print Printer Config menu on the LCD
- 2) Press the power button (Print) to run the self-test.
- 3) The printer settings information is printed on the first page, and the wireless interface information is printed on the next page.
- 4) After the wireless interface information is printed, the self-test is automatically terminated.

4-2 Self-Test Sample

BIXOLON XM7-30 CONFIGURATION	
FIRMWARE VERSION	: V01.00 STD 010118
EMULATION	: SLCS & BPL-Z & BPL-C
PRINT DARKNESS	: 0/30
PRINT SPEED	: 5 IPS
TEAR OFF VALUE	: +000 DOT
TEAR OPTION	: TEAR-OFF
PRINT OFFSET	: +0000 DOT
POWER-UP ACTION	: NO ACTION
MEDIA TYPE	: BLACKMARK MEDIA(REAR)
SENSOR TYPE	: REAR REFLECT
PRINT METHOD	: DIRECT THERMAL
LABEL LENGTH	: 1013 DOT
LABEL WIDTH	: 576 DOT
BAUD RATE	: 115200
PARITY	: NONE
DATA BIT(S)	: 8
STOP BIT(S)	: 1
HAND SHAKING	: HARDWARE
USB SERIAL NUMBER	: 0000000000001
BPL-Z CODEPAGE	: CP-850(SBE. USA-1 CHARSET)
SLCS CODEPAGE	: WCP1252-LATIN1
SLCS ICS	: U.S.A
CONFIGURATION CONTROL STATUS	
PRINT SPEED	: COMMAND
PRINT DARKNESS	: COMMAND
PRINT WIDTH	: COMMAND
PRINT OFFSET	: COMMAND
TEAR OFF	: COMMAND
MEDIA TYPE	: COMMAND
LANGUAGE	: COMMAND

(Bluetooth)

RF INTERFACE STATUS (BT)

BLUETOOTH F/W VER : 2.0.4
MAC ADDRESS



74F07DE3D121

FRIENDLY NAME : XM7-30
MODE : CLASSIC
AUTH & ENCRYPT : ENABLED
CONNECTION MODE : 2

(Wireless LAN)

RF INTERFACE STATUS (WLAN)

WLAN F/W VER : 02.02(4002)
MAC ADDRESS



74F07DE3D121

SYSTEM NAME : XM7-30
NETWORK MODE : SOFT AP
FREQUENCY : (PRIORITY)2.4GHZ/5GHZ
AUTHENTICATION : OPEN
ENCRYPTION : NONE
ESSID : PRINTER_E3D121
DHCP : DISABLED
IP ADDRESS : 192.168.1.1
NETMASK : 255.255.255.0
GATEWAY : 192.168.1.2
PORT : 9100
INACTIVITY TIME : 10 SEC

5. Cleaning

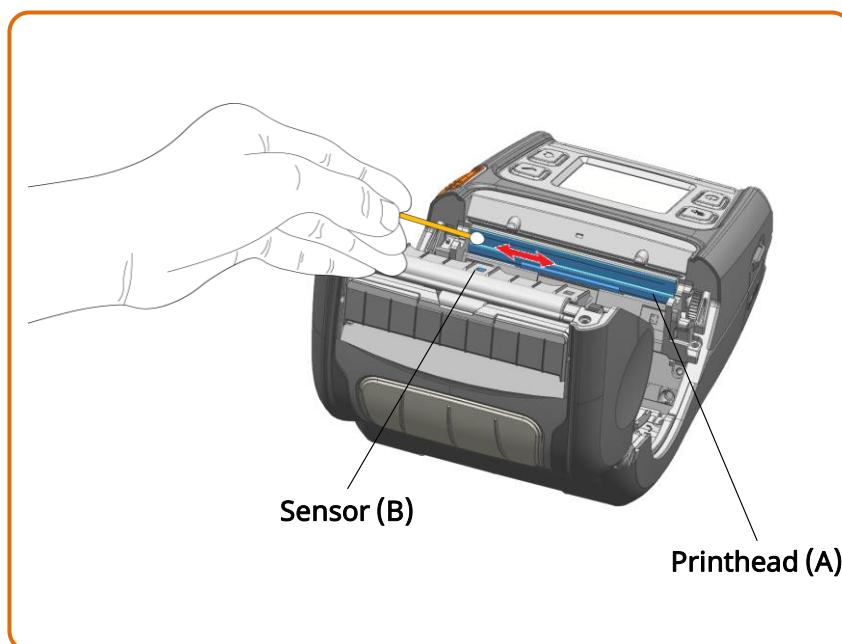

- 1) Turn off the printer and disconnect all cables from the product.
- 2) Open the media cover and remove any media inside.
- 3) Clean the printhead (A) using the cloth or cotton swab soaked in alcohol for medical.
- 4) Using the cloth or cotton swab soaked in alcohol for medical, remove the media dust from the black mark sensor (B).
(Sensor could be located in the middle or on left or on right)
- 5) Do not use the printer for one to two minutes after cleaning until the alcohol for medical has completely evaporated and dried.
- 6) Insert the media and close the media cover.



- The head is very hot while the printer is running.
When cleaning the head, be careful not to touch the heating part of the head with your hands.
- The head may be damaged by static electricity, etc.
- Be careful not to scratch the head.
- Be sure to use only genuine linerless media supplied by Bixolon.
Otherwise, post-sale support may not be available.
- Be sure to turn off the power before you proceed with cleaning.
- When using linerless media, clean the head periodically after using 4 rolls of media (100 m) or at least once a week.
Otherwise, the product may fail and print quality may be compromised.

6. Appendix

6-1 Printer Specifications

Item		Description	
Model		XM7-30	
Printing	Printing Method	Direct Thermal Printing	
	Print Speed	Up to 127 mm/s (5 ips)	
	Resolution	203 dpi	
	Font	10 SLCS Resident Bitmap Fonts One SLCS Resident Scalable Font 16 BPL-Z™ Resident Bitmap Fonts One BPL-Z™ Resident Scalable Font 7 BPL-C™ Resident Bitmap Fonts 23 Code Page Unicode supported (UTF-8, UTF-16LE, UTF-16BE)	
	Barcode	1D: Codabar, Code 11, Code 39, Code 93, Code 128, EAN-13, EAN-8, Industrial 2-of-5, Interleaved 2-of-5, Logmars, MSI, Plessey, Postnet, GS1 DataBar (RSS-14), Standard 2-of-5, UPC/EAN extensions, UPC-A, UPC-E, IMB 2D: Aztec, Codablock, Code 49, Data Matrix, MaxiCode, MicroPDF417, PDF417, QR code, TLC 39	
	Emulation	SLCS, BPL-Z™, BPL-C™	
	Sensor	Gap Sensor, Black Mark Sensor, Media Cover Open Sensor, Peel-off Sensor	
	Cutter Type	Tear-Bar	
Media	Type	Label media	Linerless media
	Outer Diameter of Media Roll	Max. Ø66 mm (2.60 inch)	Max. Ø66 mm (2.60 inch)
	Width	25 ~ 80 mm (0.99 ~ 3.15 inch)	25 ~ 80 mm (0.99 ~ 3.15 inch)
	Thickness	0.07~0.19 mm	0.08 ± 0.01mm
Reliability	Printer	25 km (Label media), 10 km (Linerless media)	
	Battery	Rechargeable up to 300 times	
Communications	Interface	Serial, USB (14Pin) / TYPE-C USB, Bluetooth V5.2 (MFi certified), NFC Auto pairing, Wireless LAN 802.11 a/b/g/n	
AC/DC Adapter	Input	Voltage: 100 ~ 240 VAC, 50/60 Hz Current: 1 A	
	Output	Voltage: 9 VDC Current: 2 A	
Battery	Type	Smart Battery (Lithium-ion)	Battery (Lithium-ion)
	Output	Voltage: 7.2 VDC (Available 8.4 ~ 6.9 VDC) Capacity: 3,400 mAh	Voltage: 7.3 VDC (Available 8.4 ~ 6.9 VDC) Capacity: 2,750 mAh
	Charging Time	Within 3 hours * Charging current and charging time may depend on the type (optional) of charger.	Within 3 hours * Charging current and charging time may depend on the type (optional) of charger.

Usage Conditions	Temperature	Printer Operating: -15 ~ 50 °C (5 ~ 122 °F) Printer Storage: -30 ~ 70 °C (-22 ~ 158 °F) Charging: 0 ~ 50 °C (32 ~ 122 °F) * Refer to the temperature conditions on Battery Safety Warning
	Humidity	Printer Operating: 10 ~ 80 % RH (No condensation) Printer Storage: 10 ~ 90 % RH (No condensation) Battery Operating: 20 ~ 70 % RH (No condensation) * Refer to the temperature conditions on Battery Safety Warning
Dimensions	Printer	119 × 180 × 79 mm (4.69 × 7.09 × 3.12 inch)
Weight	Printer	Printer: approx. 675 g (1.49 lbs) Printer+Battery: approx. 795 g (1.76 lbs) Printer+Battery+Media: approx. 1055 g (2.33 lbs) Package: approx. 1,400 g (3.09 lbs)
Accessories	Basic Items	Smart Battery, AC/DC Adapter, Belt Strap, Installation Guide, Media Disks
	Optional Items	Battery, Shoulder Strap, Interface Cable, Fixed Interface Cable, Single Battery Charger, Quad Battery Charger, Vehicle Adapter

