

TM-T88VII

Technical Reference Guide

Product Overview

Describes features of the product.

Setup

Describes setup and installation of the product and peripherals.

Advanced Usage

Describes advanced usage methods for the product.

Application Development Information

Describes how to control the printer and necessary information when you develop applications.

Handling

Describes how to handle the product.

Replacement of the TM-T88VI/TM-T88V

Describes precautions for replacement.

Appendix

Describes general specifications and character code tables.

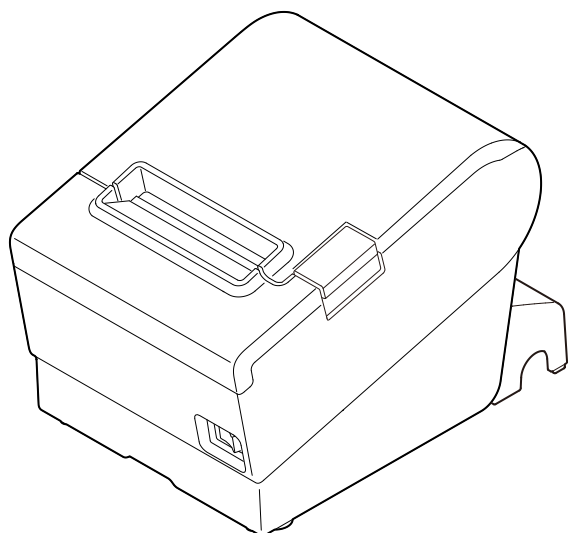

Cautions

- No part of this document may be reproduced, stored in a retrieval system, or transmitted in any form or by any means, electronic, mechanical, photocopying, recording, or otherwise, without the prior written permission of Seiko Epson Corporation.
- The contents of this document are subject to change without notice. Please contact us for the latest information.
- While every precaution has been taken in the preparation of this document, Seiko Epson Corporation assumes no responsibility for errors or omissions.
- Neither is any liability assumed for damages resulting from the use of the information contained herein.
- Neither Seiko Epson Corporation nor its affiliates shall be liable to the purchaser of this product or third parties for damages, losses, costs, or expenses incurred by the purchaser or third parties as a result of: accident, misuse, or abuse of this product or unauthorized modifications, repairs, or alterations to this product, or (excluding the U.S.) failure to strictly comply with Seiko Epson Corporation's operating and maintenance instructions.
- Seiko Epson Corporation shall not be liable against any damages or problems arising from the use of any options or any consumable products other than those designated as Original Epson Products or Epson Approved Products by Seiko Epson Corporation.

Trademarks

Microsoft, Windows, and Windows Vista are registered trademarks of Microsoft Corporation in the United States and/or other countries.

Wi-Fi®, WPA™, and WPA2™ are either registered trademarks or trademarks of Wi-Fi Alliance®.

The Bluetooth® word mark and logos are registered trademarks owned by Bluetooth SIG, Inc. and any use of such marks by Seiko Epson Corporation is under license.

IOS is a trademark or registered trademark of Cisco in the U.S. and other countries and is used under license.

Apple, Apple TV, Apple Watch, iPad, iPad Air, iPad Pro, iPhone, and Lightning are trademarks of Apple Inc., registered in the U.S. and other countries. tvOS is a trademark of Apple Inc.

iBeacon is a trademark of Apple Inc.

Android™ is a trademark of Google LLC.

Google Play and the Google Play logo are trademarks of Google LLC.

QR Code is a registered trademark of DENSO WAVE INCORPORATED in Japan and other countries.

All other trademarks are the property of their respective owners and used for identification purpose only.

ESC/POS Command System



Epson ESC/POS is a proprietary POS printer command system that includes patented or patent-pending commands. ESC/POS is compatible with most Epson POS printers and displays.

ESC/POS is designed to reduce the processing load on the host computer in POS environments. It comprises a set of highly functional and efficient commands and also offers the flexibility to easily make future upgrades.

For Safety

Key to Symbols

The symbols in this manual are identified by their level of importance, as defined below. Read the following carefully before handling the product.

 WARNING	You must follow warnings carefully to avoid serious bodily injury.
 CAUTION	Provides information that must be observed to prevent damage to the equipment or loss of data. <ul style="list-style-type: none">• Possibility of sustaining physical injuries.• Possibility of causing physical damage.• Possibility of causing information loss.
CAUTION	Provides information that must be observed to avoid damage to your equipment or a malfunction.
NOTE	Provides important information and useful tips.

Warnings

 WARNING	<p>In the following cases, immediately unplug the AC cable and contact qualified service personnel. Continued use may lead to fire or electric shock.</p> <ul style="list-style-type: none">• If the product emits smoke, a strange odor, or unusual noises.• If water or other liquid spills into the product.• If the product is too hot to touch or the case is deformed. <p>Note the following points to avoid accidents such as fire, electric shock, or burn.</p> <ul style="list-style-type: none">• Do not use this product where flammable fumes from gasoline, benzene, thinner, or other flammable liquids may be in the air.• Do not use aerosol sprayers containing flammable gas inside or around the product.• Do not cover the product with cloth, or place the product in locations subject to high levels of humidity or dust.• Do not allow foreign objects or flammable objects to fall into the equipment.• Do not touch the inside of the product except where mentioned in the manual.• Do not use the product with any power supply or voltage other than the ones specified.• Do not connect cables in ways other than those mentioned in the manual.• Never disassemble or modify the product.• Do not use the power plug if there is dust or foreign matter attached.• Do not bend, twist, pull with excessive force, or place heavy object on the AC cable.• Do not use the cables if they are damaged.• Do not place multiple loads on the power outlet (wall outlet).• Never insert or disconnect the power plug with wet hands.
---	--

Cautions



CAUTION

Note the following points to avoid injury or malfunction.

- Setup the product on a firm, stable, horizontal surface.
- Do not place heavy objects on top of the product. Never stand or lean on the product.
- Do not press your hands or fingers against the cutter when removing printed paper or loading/replacing roll paper.
- Do not put your hands between the cover and the body of the product when opening/closing the cover.
- Never attempt to repair the product yourself.
- Do not connect a telephone line to the drawer kick connector.

To ensure safety, unplug this product before leaving it unused for an extended period.

CAUTION

If this product is used in a place where silicon-based gases including siloxane (silicon adhesive, silicon oil, silicon powder, etc.) or malignant gases (nitric acid, hydrogen sulfide, ammonia, chlorine, etc.) are present in the air, contact failure may occur in mechanical contacts such as mechanical switch or DC motor in a short time due to adhesion or oxidation of the insulation film.

Caution Labels

The caution labels on the product indicate the following precautions.



Do not touch the thermal head and the frame on its side because it can be very hot after printing.



Touching the manual cutter may cause injury.

Restriction of Use

When this product is used for applications requiring high reliability/safety, such as transportation devices related to aviation, rail, marine, automotive, etc.; disaster prevention devices; various safety devices, etc.; or functional/precision devices, etc., you should use this product only after giving consideration to including fail-safes and redundancies into your design to maintain safety and total system reliability. Because this product was not intended for use in applications requiring extremely high reliability/safety, such as aerospace equipment, main communication equipment, nuclear power control equipment, or medical equipment related to direct medical care, etc., please make your own judgment on this product's suitability after a full evaluation.

Note about interference

- This product generates, uses, and can radiate radio frequency energy and, if not installed and used in accordance with the instruction manual, may cause harmful interference to radio communications.
- If this equipment does cause harmful interference to radio or television reception, which can be determined by turning the equipment off and on, the user is encouraged to try to correct the interference by one or more of the following measures:
 - Reorient or relocate the receiving antenna for the radio/TV.
 - Increase the separation between the equipment and the radio/TV.
 - Connect the equipment into an outlet on a circuit different from that to which the receiver is connected.
 - Consult your dealer or an experienced radio/TV technician for help.
- Never disassemble or modify this product.
- Seiko Epson Corporation shall not be liable for interference to radio/TV resulting from changes or modifications to this product not expressly approved by Seiko Epson Corporation.

Open Source Software License

This product uses open source software in addition to Epson proprietary software.

For information of the open source software used in this product, see the following URL.

<http://xxx.xxx.xxx.xxx/PRESENTATION/ADVANCED/LICENSE/TOP>

For “xxx.xxx.xxx.xxx” in the above URL, input your printer’s IP address.

About this Manual

Aim of the Manual

This manual provides developers/engineers with all the necessary information for design, development and installation of a POS system, and also design and development of a printer application.

NOTE

For Users in Europe, the Middle East and Africa

Models that comply with the cybersecurity requirements of the European Radio Equipment Directive (RED) 2014/53/EU have had changes made to specifications related to network communications, such as enhanced security.

These specification changes affect when using wired LAN, wireless LAN, and Bluetooth with compliant models.

For information on how to identify whether a product is compliant, the specifications of compliant products, and precautions for use, refer to the Cybersecurity Enhancement Supplementary Guide published on the model-specific manual page at the URL below.

[🔗 https://epson.sn](https://epson.sn)

Manual Content

The manual is made up of the following sections:

Chapter 1	Product Overview
Chapter 2	Setup
Chapter 3	Advanced Usage
Chapter 4	Application Development Information
Chapter 5	Handling
Chapter 6	Replacement of the TM-T88VI/TM-T88V
Appendix	Product Specifications Specifications of Interfaces and Connectors Bluetooth Low Energy Technology Advertising Character Code Tables

Contents

■ For Safety	3
Key to Symbols.....	3
Warnings	3
Cautions.....	4
■ Caution Labels	5
■ Restriction of Use	5
■ Note about interference	5
■ Open Source Software License.....	5
■ About this Manual	6
Aim of the Manual	6
Manual Content.....	6
■ Contents.....	7

Product Overview

■ Features	12
■ Product Configurations	14
Models.....	14
Accessories	14
■ Part Names and Functions	15
Control Panel	16
Connectors	17
Online and Offline.....	19
■ Status and Errors	20
Status Display	20
Network Connection Status	21
Error Status	21
■ NV Memory	24
NV Graphics Memory	24
User NV Memory	24
Memory Switches.....	24
R/E (Receipt Enhancement).....	24
Maintenance Counter.....	25
■ Simple Setup for Wireless LAN	26
■ Useful Functions for Smart Devices.....	27
NFC Tag	27
QR Code.....	27
■ Printing Using Multiple Interfaces.....	28

Setup	29
■ Flow of Setup	29
■ Installing the Printer	30
Important Notes on Horizontal Installation	30
Important Notes on Wall Hanging	30
■ Adjusting the Paper Roll Near-End Sensor.....	31
■ Connecting the AC adapter.....	33
Connecting the AC adapter.....	33
■ Connecting the Printer to the Host.....	34
USB Interface	34
Ethernet Interface	34
Wireless LAN Interface (With OT-WL06)	35
Serial Interface	40
Parallel Interface	40
USB Plus Power Interface	40
■ Connecting the Cash Drawer	41
Cash Drawer Requirements	41
Connecting the drawer kick cable	42
■ Setting the Built-in Buzzer (for Models with a Built-in Buzzer)	43
Using Epson TM Utility	43
Using TM-T88VII Utility	44
■ Connecting the Optional External Buzzer	45
Attachment Position	45
■ Connecting the Optional Wireless LAN Unit.....	46
■ Connecting the Optional Customer Display	46
■ Attaching the Connector Cover.....	47
■ Arranging the Cables.....	49
■ Attaching the Power Switch Cover	51
■ Changing the Paper Width	52
■ RTC Settings	53

Advanced Usage **54**

■ Setting the DIP Switches.....	54
Setting Procedure	54
Serial Model	56
Parallel Model/Powered USB Model.....	58
Fixed Interface Model	60
Selecting the BUSY Status.....	61
■ Software Settings.....	62
Functions.....	64

■ Setting/Checking Modes	73
Self-test Mode	75
NV Graphics Information Print Mode (NV Graphics Information)	75
Receipt Enhancement Information Print Mode (Receipt Enhancement Information)	76
Software Setting Mode (Customize Value Settings)	77
Restore Default Values Mode (Restore Default Values)	79
Interface Setup Mode (Interface Setup)	80
TM-Intelligent Settings Information Print Mode (TM-Intelligent Information)	81
Peripheral Device Information Print Mode (Peripheral Device Information)	81
Hexadecimal Dumping Mode	82
■ Printing a Status Sheet	83
■ Network Connection Check	86
Printing a Network Connection Check Report	86
List of Errors	86
■ Resetting the Interface Settings	87
■ TM-Intelligent Function	88
Server direct print	88
■ WebConfig	89

Application Development Information..... **91**

■ Controlling the Printer	91
ePOS-Print XML	91
ePOS-Device XML	91
ESC/POS	91
■ Controlling the Cash Drawer	93
■ Controlling the Built-in Buzzer	94
■ Controlling the Optional External Buzzer	95
■ Software	96
Development Kits	96
Drivers	97
Utilities	97
Others	98
Download	98
■ Notes on Printing Barcodes and Two-dimensional Symbols	99
■ Automatic Certificate Update Feature	100
Overview	100
Implementation	101
Operation Check	102

Handling

■ Installing and Replacing Roll Paper	103
--	------------

■ Removing Jammed Paper	106
■ If Roll Paper Cover does not Open	108
■ Cleaning the Printer.....	109
Cleaning the Printer Case.....	109
Cleaning the Thermal Head/Platen Roller.....	109
■ Preparing for Transport.....	110

Replacement of the TM-T88VI/TM-T88V..... 111

■ Compatibility	111
Printing	111
Print Density.....	111
Number of Head Energizing Parts.....	111
Printable Area (for 80 mm Width Paper)	111
Cutting Method	111
Manual Paper Feed	112
Receive Buffer	112
Memory Capacity.....	112
Electrical Characteristics	112
DIP Switches.....	112
Printer Status	112
Logo Registration.....	112
Driver Compatibility	112
USB Low Power Consumption Mode	112
Maintenance Counter.....	113
Buzzer	113
NFC	113
Epson TM Utility (for iOS/Android).....	113
Power Supply Box	113
Overall Dimensions	114
■ Additional Functions and Functional Improvements	115
Print Speed	115
Interface.....	115
SimpleAP Function	115
Noise	115
LED Indicator	115

Appendix..... 116

■ Product Specifications	116
Printing Specifications.....	117
Character Specifications	118
Printable Area	120
Printing and Cutting Positions	122
Paper Specifications	123
Electrical Characteristics	124

Environmental Conditions	125
External Dimensions and Mass	126
■ Specifications of Interfaces and Connectors	128
USB Interface	128
Network Interface	129
Default administrator password for setting / Default passphrase for SimpleAP	133
RS-232 Serial Interface.....	134
IEEE 1284 Parallel Interface.....	137
NFC Tag	139
■ Bluetooth Low Energy Technology Advertising.....	140
Introduction	140
Dongle specifications	140
Procedure.....	140
Changing the Bluetooth Low Energy Technology Advertising Packet.....	141
■ Character Code Tables.....	152
■ Compatibility with USB Type-A	153

Product Overview

This chapter describes features of the product.

Features

Printing

- High speed printing (500 mm/s maximum).
- Shifting from 80 mm width paper printing to 58 mm width paper printing is available.
- Multi-tone graphic printing.
- Multiple languages are supported (ANK (includes Thai), Japanese (JIS Level 1, 2, 3, and 4), Simplified Chinese, Traditional Chinese, Korean)

Handling

- Easy drop-in paper loading

Software

- TM-Intelligent function is equipped.
Supports Server Direct Print that sends a request for print data from the product to the Web server at regular intervals.
- Command protocol is based on the ESC/POS Proprietary Command System.
- OPOS ADK, OPOS ADK for .NET, JavaPOS ADK, and Windows printer drivers are available.
- In addition to supporting several kinds of bar code printing, DS1 DataBar printing and two-dimensional symbol (PDF417, QR code, MaxiCode, Composite Symbology) printing are possible.
- A maintenance counter function is supported.
- Various utility software are available.
- A utility for iOS/Android (Epson TM Utility (for iOS/Android)) for making printer settings is also provided.
- Indicates Ethernet and Wi-Fi network status separately with the two LED indicators.
- The Wi-Fi LED indicates the Wi-Fi connection status when a wireless LAN unit is installed in the printer. The status is not indicated when a UIB wireless LAN interface is used.

Environment

- Paper saving function is available.

Functions

- NFC tag* built into the printer unit for easily connecting this product to the network.
- Printing triggered by bar code/QR code scan by smart device camera.
- Supports printing using multiple interfaces.
- Enables HTTPS communication.
- Offers network connection check function.

* May not be equipped depending on the printer model.

Others

- Various interface models are available.
- Optional customer display, wireless LAN unit, external optional buzzer, and power supply box are available.
- Optional wall hanging bracket is available to attach the printer to a wall.
- Enables automatic registration and periodic update of security certificates for printers. (when using the automatic CA-signed certificates update function in application software using Epson ePOS SDK for JavaScript)

Product Configurations

Models

- Serial model: equipped with serial, Ethernet, and built-in USB interfaces
- Parallel model: equipped with parallel, Ethernet, and built-in USB interfaces
- Powered USB model: equipped with USB Plus Power, Ethernet, and built-in USB interfaces
- Fixed Interface model: equipped with Ethernet and built-in USB interfaces

NOTE

The countries and regions where the product can be used vary by model (not all models are available in each country or region).

Accessories

Included

- Roll paper (for operation check)
- Power switch cover
- Connector cover
- Screw for attaching the Connector cover (x1)
- Bottom cover for the Connector cover
- Screw for attaching the Bottom cover for the Connector cover (x2)
- Roll paper guide
- Screw for attaching the roll paper guide (x1)
- Cable lock band*
- AC adapter*
- AC cable*
- TM-T88VII User's Guide
- Warranty card*



* May not be included depending on the model.

Options

- AC adapter
- AC cable
- Power supply box (Model: OT-BX88VII)
- Wall hanging bracket (Model: WH-10)
- Interface boards (UB series)
- Optional external buzzer (Model: OT-BZ20)
- Wireless LAN cable set (Model: OT-WL06)
- Customer display (Model: DM-D30/DM-D70/DM-D110/DM-D210)

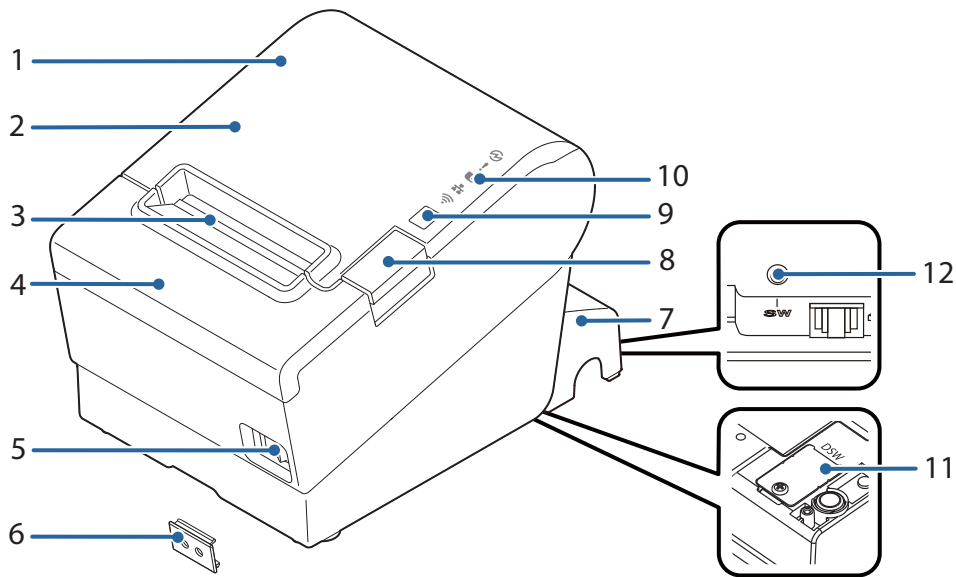
Part Names and Functions



1	NFC Tag	<p>A mark is printed here to indicate the position of the NFC tag. To establish communication with an NFC device, bring the device close to this mark. For details on functions that use the NFC tag, refer to "Useful Functions for Smart Devices" on page 27.</p> <ul style="list-style-type: none"> • There is no data rewriting function. • Use Epson ePOS SDK to build this function into your application. <p>* May not be equipped depending on the printer model.</p>
2	Roll paper cover	Open this cover to install/replace the roll paper.
3	Manual cutter	Use this cutter when you cut the roll paper manually.
4	Cutter cover	Open this cover to unlock the autocutter blade when the roll paper cover does not open due to a paper jam.
5	 Power switch	Turns the printer on or off.
6	Power switch cover	<p>Install the power switch cover onto the printer to prevent inadvertent changing of the power switch, to prevent tampering, and to improve the appearance of the printer.</p> <p>To operate the power switch, insert an object with a pointed tip such as a ballpoint pen into the hole on the power switch cover.</p> <p>For attaching the power switch cover, refer "Attaching the Power Switch Cover" on page 51.</p>
7	Connector cover	Use the printer with this cover attached to protect cables.
8	Cover open button	Use this button to open the roll paper cover.
9	 Feed button	Pressing this button once feeds roll paper for one line. Hold down this button to continue feeding roll paper.
10	Control Panel	For details on LED, see "Control Panel" on page 16 .
11	Dip switch cover	Open the cover to view the dip switches for communication settings.
12	Status sheet button	<p>Use this button to print a status sheet on interfaces or initialize the settings on interfaces.</p> <p>Fixed Interface models have the status sheet button on a different location. See "Fixed Interface Model" on page 18.</p>

NOTE

When turning off the printer without using the power switch, it is recommended to send a power-off command to the printer. If you use the power-off sequence, the latest maintenance counter values are saved. (Maintenance counter values are usually saved every two minutes.)
For information about ESC/POS commands, see the ESC/POS Command Reference.

Control Panel

Power LED

- Lights when the power supply is on.
- Off when the power supply is off.
- Flashes during the network to start up, when waiting for power off, or updating firmware.

CAUTION

Do not turn on by using the power switch while waiting for the power to turn off (when the Power LED is flashing). Otherwise, it may not startup correctly.

Error LED

- Lights or flashes when an error occurs. (For information about the flashing patterns, see ["Status and Errors" on page 20.](#))
- Lights after the power is turned on or after a reset (offline). Automatically goes out after a while to indicate that the printer is ready.
- Off when the printer is in standard mode (online).

Paper LED

- Lights when the roll paper is out.
- Flashes to urge user to operate the Feed button.

Wi-Fi LED

- Lights while the printer is connected to Wi-Fi.
- Off while the printer is not connected to Wi-Fi or while the printer is connected to a wired LAN.
- Flashes while communication is temporarily disabled because an IP address has not been acquired or for other reason.

Ethernet LED

- Lights while the printer is connected to Ethernet.
- Off while the printer is not connected to Ethernet or while the printer is connected to Wi-Fi.
- Flashes while communication is temporarily disabled because an IP address has not been acquired or for other reason.

Connectors

All connectors are located on the lower rear of the printer.

Serial/Parallel/Powered USB Models

CAUTION

- The installed interface varies depending on the model.
- Do not insert a Type-B USB connector into the LAN connector or the drawer kick connector. If it is inserted, the connector, printer, and the system may malfunction.
- If using the drawer kick connector and a serial/parallel connector simultaneously, we recommend using either of the cables below to prevent the cables from interfering with one another.
 - * Flat-type drawer kick cable
 - * Serial/parallel cable with a connector (from the tip to the screw) that is within 34 mm {1.34"}.

Within 34 mm {1.34"}.

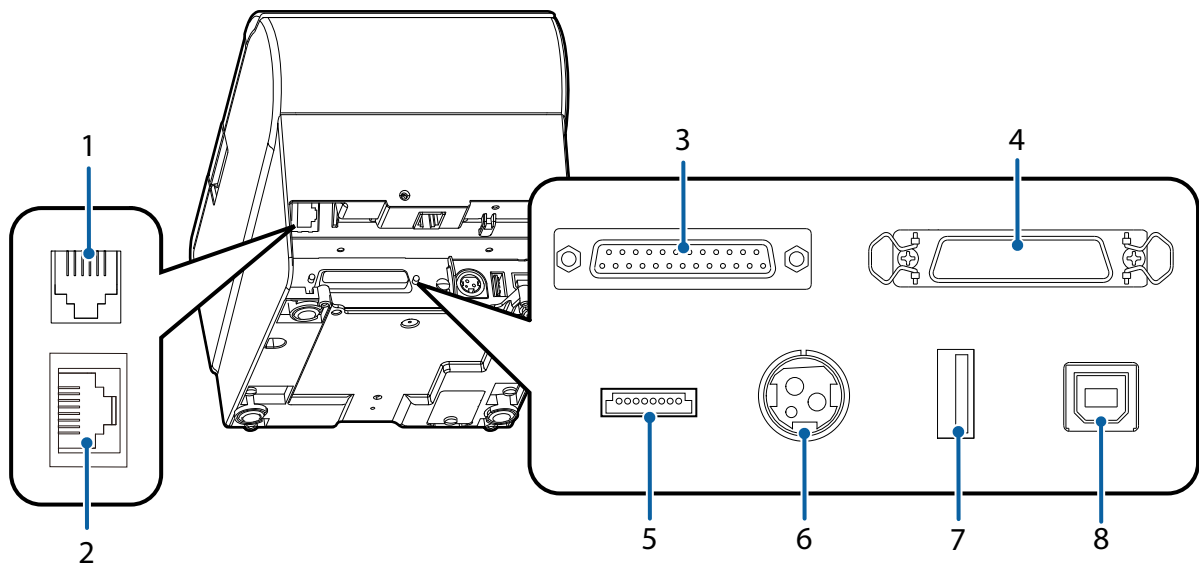
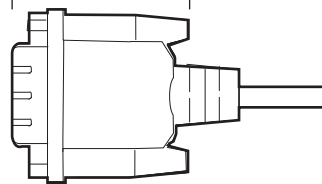

1	Drawer kick connector	Connects the cash drawer or the optional external buzzer. See "Connecting the Cash Drawer" on page 41, and "Connecting the Optional External Buzzer" on page 45.
2	Ethernet connector	Connects the 10BASE-T/100BASE-TX Ethernet cable.
3	Serial interface	Serial model only. Connects the serial cable for connecting to a computer.
4	Parallel interface	Parallel model only. Connects the parallel cable for connecting to a computer.
5	USB Plus Power Interface	Powered USB model only. Connects the USB Plus Power cable for connecting to a computer.
6	Power supply connector	Connect the AC adapter. See "Connecting the AC adapter" on page 33.

7	USB connector	Use only for connecting optional Wireless LAN unit and customer display. CAUTION: It may be hard to disconnect some types of USB cable. Do not forcibly pull the cable, or the USB connector and USB cable may be damaged. Contact qualified service personnel if you encounter the trouble.
8	USB connector (Type B)	Connects the USB cable for connecting to a computer. See " Connecting the Printer to the Host " on page 34.

Fixed Interface Model

CAUTION

Do not insert a Type-B USB connector into the LAN connector or the drawer kick connector. If it is inserted, the connector, printer, and the system may malfunction.

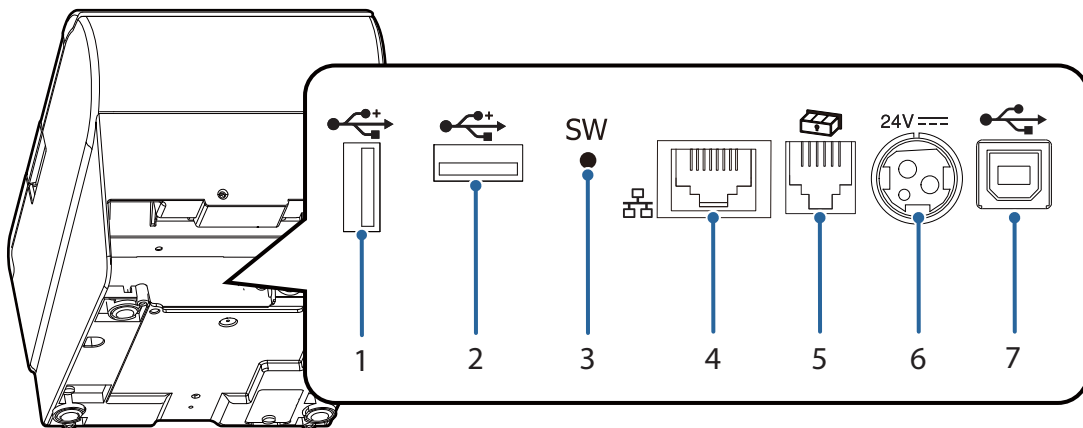

1	USB connector (Type-A)	Connects a USB cable of a peripheral device such as an optional Wireless LAN cable set, customer display, or handheld scanner.
2		
3	Status sheet button	Use this button to print a status sheet on interfaces or initialize the settings on interfaces.
4	Ethernet connector	Connects the 10BASE-T/100BASE-TX Ethernet cable.
5	Drawer kick connector	Connects the cash drawer or the optional external buzzer. See " Connecting the Cash Drawer " on page 41, and " Connecting the Optional External Buzzer " on page 45.
6	Power supply connector	Connect the AC adapter. See " Connecting the AC adapter " on page 33.
7	USB connector (Type B)	Connects the USB cable for connecting to a computer. See " Connecting the Printer to the Host " on page 34.

Online and Offline

Online

The printer is online and ready for normal printing unless there is a reason to go offline.

Offline

The printer automatically goes offline under the following conditions:

- While the printer power is turning on/off
- While a self-test is running
- While roll paper is fed using the Feed button
- When the printer stops printing due to a paper end (when the paper out detector detected the paper out)
- During an operation standby state
- When an error has occurred (See "[Status and Errors](#)" on page 20)
- While the roll paper cover is open

Status and Errors





The LEDs turn on or flash to indicate status of the printer.





NOTE

Printing is impossible while an error is occurring.

Status Display

●: OFF ○: ON ◐: Flashing -: Ignore the LED light*¹

	POWER LED 	ERROR LED 	PAPER LED 	Ethernet LED 	Wi-Fi LED 
Normal state	○	●	●	-	-
Initializing after power-on	○	○	-	●	●
Running a self-test *2	○	●	-	●	●
Waiting to continue self-test	○	●	◐*2	●	●
Feeding paper using the Feed button	○	●	-	-	-
Waiting to execute a macro	○	●	◐*2	-	-
Roll paper cover open while not printing	○	○	-	-	-
No paper	○	○	○	-	-
Remaining amount of roll paper is low	○	●	○	-	-
Updating firmware	◐*2	●	●	●	●
Waiting for power off NOTE: This indicates that the printer is ready for power off without using the power switch. The printer enters this state after executing a power-off command. When turning off without using the power switch, it is recommended to use the power-off command.	○	○	●	●	●
Waiting for the roll paper cover to be closed to print a status sheet	○	●	◐*2	●	●
During power-off standby process / During power-off process	◐*2	○	●	●	●
Network is starting up + Link down indication	○	●	●	◐*2	◐*2
Printer reset in process / initialization of communication settings in process	◐*2	●	●	-	-

	POWER LED 	ERROR LED 	PAPER LED 	Ethernet LED 	Wi-Fi LED 
Warning about TM-Intelligent function / Warning about Network function	◐ *3	●	●	-	-
The connected device can only be charged through the USB port.	○	◐ *4	●	-	-
A USB hub is connected.	○	◐ *5	●	-	-

*1: Depends on the paper sensor status and the interface communication status.

*2: The LED flashing pattern repeats 0.32 s on, 0.32 s off.





*3: The LED flashing pattern repeats 0.496 s on, 0.016 s off.

*4: The LED flashing pattern repeats 0.32 s on, 0.32 s off for 5 s, and finally turns off.

*5: The LED flashing pattern is: 0.32 s on, 0.32 s off, 0.64 s on, and finally turns off.

Network Connection Status

●: OFF ○: ON ◐: Flashing

	POWER LED 	ERROR LED 	PAPER LED 	Ethernet LED 	Wi-Fi LED 
Connected to Ethernet	○	●	●	○	●
In the process of connecting to Ethernet (An IP address has not been acquired)	○	●	●	◐	●
Connected to Wi-Fi	○	●	●	●	○
In the process of connecting to Wi-Fi (An IP address has not been acquired)	○	●	●	●	◐
Not connected to network	○	●	●	●	●

The LED flashing pattern repeats 0.32 s on, 0.32 s off.



Error Status

There are three possible error types: automatically recoverable errors, recoverable errors, and unrecoverable errors.

Automatically Recoverable Errors

Printing is impossible while an automatically recoverable error is occurring. The printer recovers from the error as described below.

Error	Explanation	Error LED Flashing Pattern	Recovery measure
Print head high temperature error	A high temperature beyond the standard range for driving the head is detected.		The printer recovers from the error when the head temperature drops.

Error	Explanation	Error LED Flashing Pattern	Recovery measure
Cover open error	The roll paper cover is opened during printing.		The printer recovers from the error when the cover is closed.
Motor driver IC high temperature error	A high temperature beyond the standard range for driving the motor is detected.		The printer recovers from the error after the elapse of a certain period of time.
Motor heating error	A high temperature beyond the standard range for driving the motor is detected.		The printer recovers from the error after the elapse of a certain period of time.

Recoverable Errors

Printing is impossible while a recoverable error is occurring. After the error cause is eliminated, the printer recovers from the error when it is turned off and back on or receives an error recovery command.

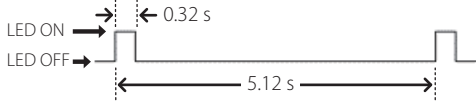
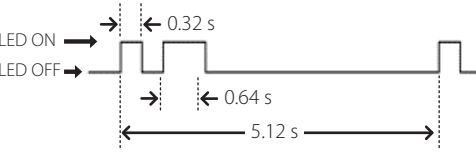
Error	Explanation	Error LED Flashing Pattern	Recovery measure
Auto cutter error	The autocutter does not work properly.		To recover from the error, remove the jammed paper or foreign objects and then do one of the following: <ul style="list-style-type: none"> - Close the roll paper cover - Send an error recovery command after closing the roll paper cover
Paper jam error	The roll paper is jammed.		To recover from the error, remove the jammed paper or foreign objects and then do one of the following: <ul style="list-style-type: none"> - Close the roll paper cover - Send an error recovery command after closing the roll paper cover

NOTE

The error recovery command is valid only if a recoverable error (excluding automatically recoverable errors) occurs.

Unrecoverable Errors

Printing is impossible while an unrecoverable error is occurring. If the error still occurs after turning the printer off and then back on, the printer may be defective. Contact qualified service personnel.



Turn off the power immediately when unrecoverable errors occur.

Error	Explanation	Error LED Flashing Pattern
Internal circuit connection error	Internal circuits are not connected correctly.	
Memory reading/writing error	After a reading/writing check of the memory, the printer does not work correctly.	
High voltage error	The power supply voltage is extremely high.	
Low voltage error	The power supply voltage is extremely low.	
CPU execution error	The CPU is executing an incorrect address.	
Communication unit error	An error has occurred in the communication unit.	
Reversing error	The motor is reversing.	
Driving time error	The motor driving time has exceeded the limit.	
Oscillation error	The motor is oscillating.	

NV Memory

The printer's NV memory (Non-Volatile Memory) stores data even after the printer power is turned off. NV memory contains the following memory areas for the user:

- NV graphics memory
- User NV memory
- Memory switches
- R/E (Receipt Enhancement)
- Maintenance counter



NV memory can be rewritten about 100,000 times. As a guide, NV memory rewriting should be 10 times or less a day when you program applications.

NV Graphics Memory

Graphics, such as shop logos to be printed on receipts, can be stored. Even with a serial interface model whose communication speed is low, high speed graphics printing is possible.

To register your graphics data, use TM-T88VII Utility or ESC/POS commands.

You can check registered graphics data using TM-T88VII Utility or by printing the data in the NV graphics information print mode.

User NV Memory

You can store and read text data for multiple purposes, such as for storing a note including customizing or maintenance information of the printer.

Memory Switches

With the memory switches, which are software switches for the printer, you can configure various settings of the printer. For information about the memory switch, see ["Software Settings" on page 62](#).

R/E (Receipt Enhancement)

You can set the graphics data, such as a shop logo, registered in the NV graphics memory to be printed on the top of each receipt or to be printed on the bottom of each receipt just before the paper is cut.

To make the settings, use TM-T88VII Utility or ESC/POS commands.

You can check the settings using TM-T88VII Utility or by printing the settings information in the Receipt enhancement information print mode.

Maintenance Counter

With this function, printer information, such as the number of lines printed, the number of autcuts, and printer operation time after the printer starts working, is automatically stored in NV memory.

NOTE

- You can also check the head running length and number of times of autcutting with the self-test (see ["Self-test Mode" on page 75](#)).
- The maintenance counter values are automatically saved in the NV memory usually every two minutes (up to four minutes). However, the values are not saved when the printer is in power-saving mode or when it is turned off without the use of the power switch.

Simple Setup for Wireless LAN

The printer has "SimpleAP" mode that allows a device to directly connect to the printer without using an access point. You can configure wireless LAN settings using the printer setting tool and print on the printer using the direct connection.

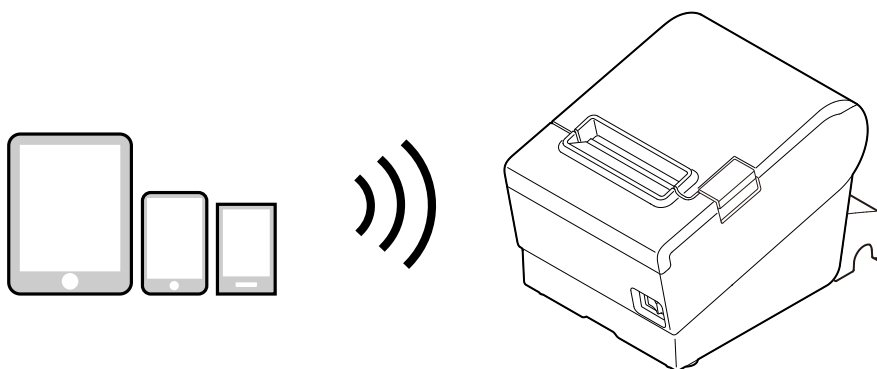

NOTE

- The printer acts as an access point in the SimpleAP mode and allows up to eight devices to connect to the printer.
- Connection to a wireless LAN or wired LAN and connection using the SimpleAP mode can be made at the same time.
- Communication between devices connected to the printer in the SimpleAP mode is impossible.
- If the printer is already connected to a wireless LAN and setting using the SimpleAP mode is started, the wireless LAN connection is temporarily disconnected.
- Since the default IP address of SimpleAP is 172.16.10.1, do not use 172.16.x.x as the IP address for the wireless LAN or wired LAN. If you use it, the SimpleAP function will stop to avoid IP address conflicts. However, if you restart SimpleAP in the above state, you can start SimpleAP with IP address conflict avoided.
- If you change the passphrase, connection using SimpleAP from an Android 10 device is disabled. It may also occur with a device running other OS. If that happens, delete the printer's SimpleAP SSID profile in the Wi-Fi settings of the Windows, iOS, or Android device, and then connect to the printer again.
- You may be requested to enter the passphrase, even if you have not changed the passphrase. For the default passphrase, see "[Default administrator password for setting / Default passphrase for SimpleAP](#)" on page 133.

SimpleAP is enabled by default.

The printer will automatically print the information shown below if the printer is turned on with the following conditions; the optional wireless LAN unit is used, SimpleAP is enabled, the printer is not connected to a wireless/wired LAN or to a USB device, the printer's wireless LAN settings have not been configured.



The printer activates SimpleAP when it is turned on for the first time, however, if you change the printer settings using TM-T88VII Utility (for Windows) or EpsonNet Config, SimpleAP is disabled.

To activate SimpleAP again, start it by selecting the SimpleAP menu that is available after printing a status sheet, or reset the network settings.

["Setting up from a Windows Computer using SimpleAP" on page 36](#)

["Resetting the Interface Settings" on page 87](#)

Useful Functions for Smart Devices

You can easily connect this product to the network by using the NFC tag* built-in to the printer or the QR code printed on the status sheet.

* May not be equipped depending on the printer model.

NFC Tag

Bring a smart device that supports NFC close to the NFC tag to acquire the printer information (information for specifying the device).

Specify the target printer using the acquired information to connect to the network.

QR Code

Capture the QR code printed on the status sheet with the camera on your smart device to acquire the printer information (information for specifying the device).

Specify the target printer using the acquired information to connect to the network.

NOTE

- Programming using Epson ePOS SDK is required to use these functions. These functions are created by combining NFC touch and QR code capturing operations and the target printer specifications using Printer Easy Select API. See the "Epson ePOS SDK for Android/iOS User's Manual" and the Epson ePOS SDK sample program for more details. The sample program also contains a sample implementation method for reading an NFC tag and capturing a QR code.
- You can try a demo of these functions by using Epson TM Utility (for iOS/Android).

Printing Using Multiple Interfaces

In printers with multiple interfaces, you can use all interfaces without any limitations on which interface is to be used. You can use this function to temporarily connect a smart device to a nearby printer and print.

The printer provides each interface with an independent receive buffer and switches the active interface depending on the priority, while handling data in each receive buffer.

You can set one interface for the main connection. Data received from the main connection interface is handled with the highest priority.

By default, the interface that receives the first data transfer is set as the main connection interface; however, you can select the main connection interface in advance.

When the receive buffer for the active interface becomes empty and a preset time period has passed, switching to another interface is enabled, and an interface that receives print data becomes active.

CAUTION

You cannot use wired and wireless LANs at the same time. When a LAN cable is connected, wireless LAN is disabled.

NOTE

You can select the main connection interface and set the time to enable interface switching from the software settings. For details on software settings, see ["Software Settings" on page 62](#).

Setup

This chapter describes setup and installation of the product and peripherals.

Flow of Setup

This chapter consists of the following sections along with the setup flow of the product and peripherals.

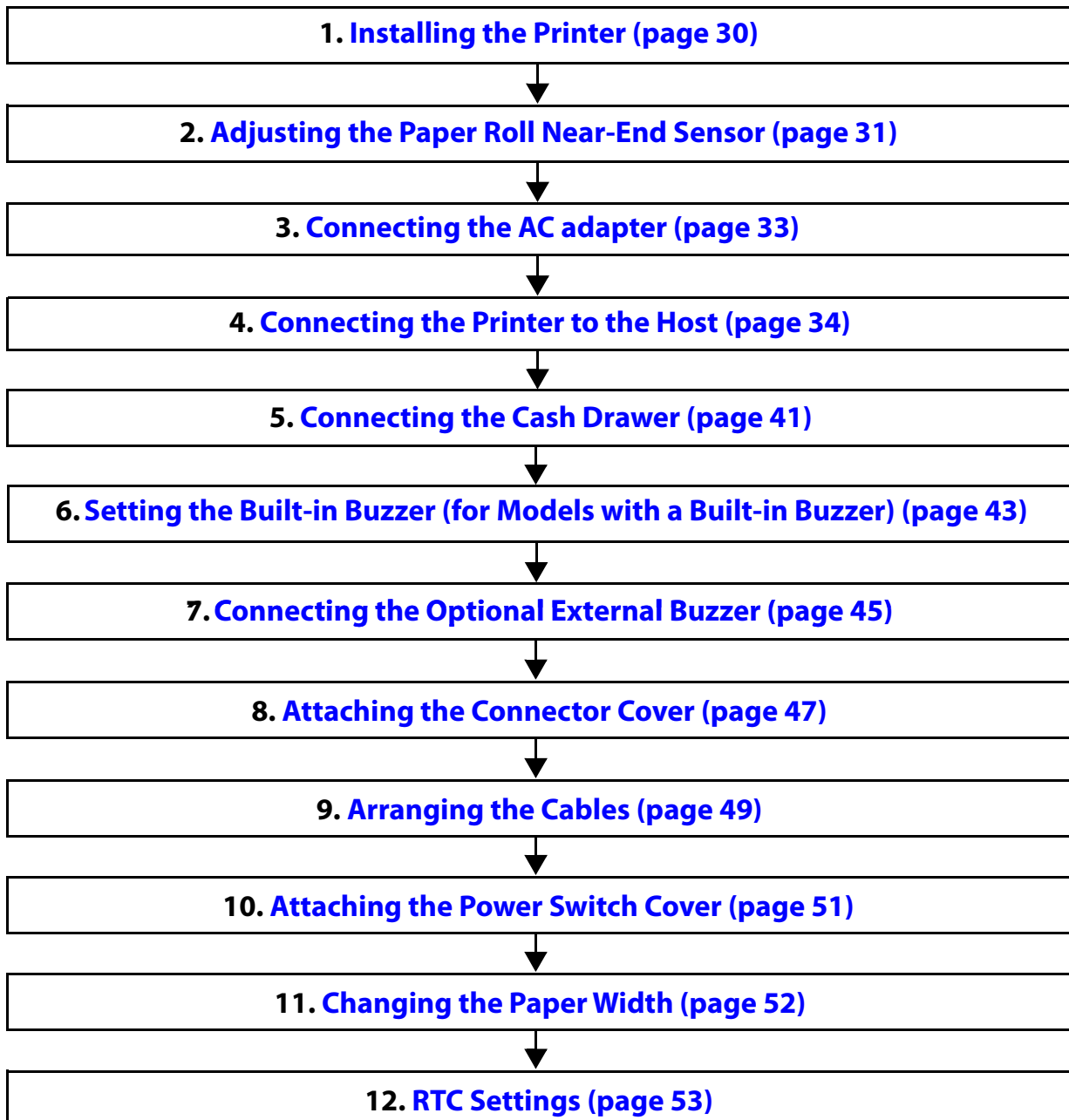

Installing the Printer

You can install this printer horizontally. With an optional hanging bracket (WH-10), you can also attach the printer to a wall.

Important Notes on Horizontal Installation

- The printer must be installed horizontally on a flat surface (not tilted).
- Do not place the printer in dusty locations.
- Do not catch cables or place foreign matter under the printer.

Important Notes on Wall Hanging

You need to perform the following tasks to install the printer on a wall. For more details, see the installation manual for the optional wall hanging bracket (WH-10).

- Installing the roll-paper stoppers
- Changing the location of the roll paper near-end sensor
- Attaching the connector cover
- Attaching the wall hanging bracket (WH-10)

For the other notes, see the installation manual for the optional wall hanging bracket (WH-10).

CAUTION

- Be sure to attach the connector cover when you install the printer on a wall using the wall hanging bracket.
- When installing on a wall using a wall mounting bracket, the status of the wireless signal for the wireless LAN unit may decline. In this situation, use an extension cable.

Adjusting the Paper Roll Near-End Sensor

Below are two situations where a roll paper NE sensor adjustment is required.

- To adjust the detection position to suit the diameter of the roll paper core used.
- To adjust the detection position of remaining amount of paper.

CAUTION

- Since roll paper cores vary slightly in shape, depending on paper roll design and manufacturing tolerances, it is impossible to detect the remaining paper exactly.
- To let the NE sensor detect remaining amount of paper accurately, it is recommended to use a roll paper with a core inner diameter of 12 mm {0.47"} and outer diameter of 18 mm {0.71"}.
- An outer diameter of a paper roll that is detected as near-end varies by usage environment, and/or paper specifications. Please check operation of the NE sensor by yourself.

Follow the steps below to adjust the roll paper near-end sensor.

- 1 Open the roll paper cover, and remove the roll paper.
- 2 Loosen the adjustment screw fastening the sensor, and then operate the knob to align the top edge of the positioning plate with the upper or lower level.

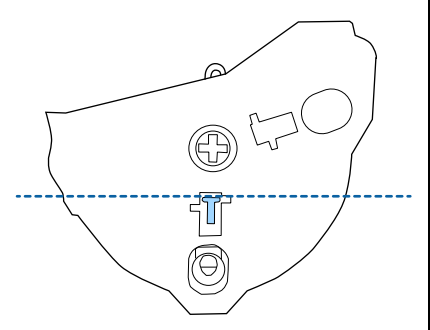
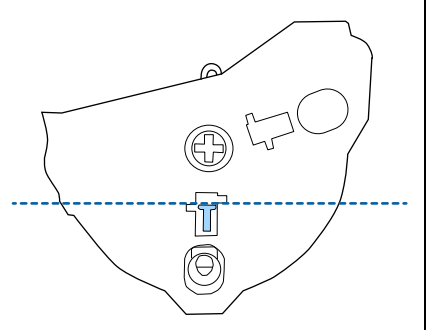
Adjustment position	Upper	Lower
Outer diameter of a roll to be detected as near-end	Approx. 27 {1.06"}	Approx. 23 {0.97"}
Position of the positioning plate		

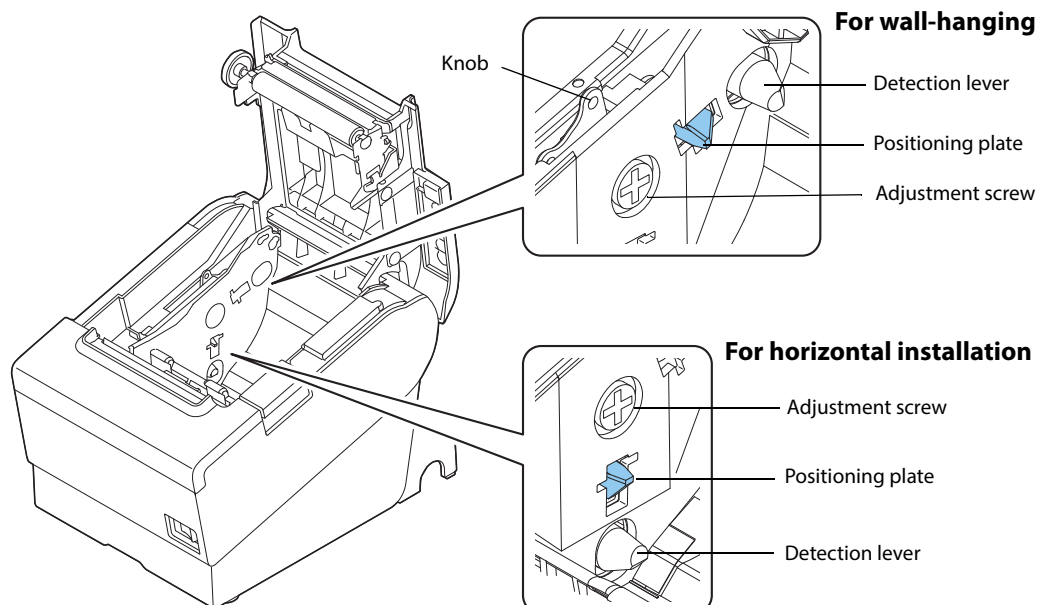

- 3** Tighten the adjustment screw.
- 4** After adjustment, make sure that the detection lever operates smoothly.

Connecting the AC adapter

Use the Epson PS-190 or an equivalent product as the AC adapter.



- Never insert the AC cable plug into a socket that does not meet the input voltage of the AC adapter. Doing so may result in damage to the printer.
- Should a fault ever occur, immediately turn off the power to the printer and unplug the AC cable from the socket.

Connecting the AC adapter

- 1 Make sure the printer is turned off.
- 2 Connect the AC cable to the AC adapter.

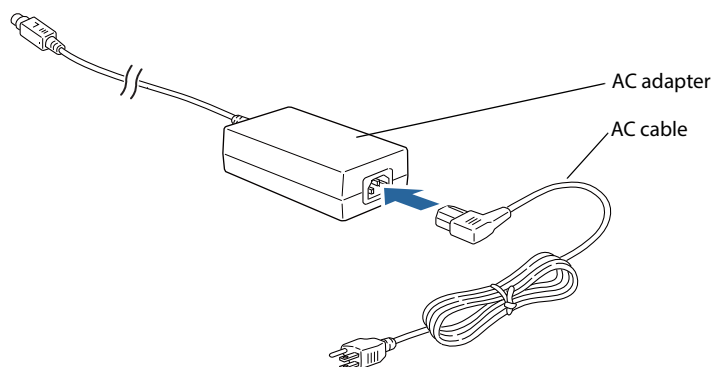

- 3 Connect the DC cable of the AC adapter to the power supply connector (stamped 24V).

NOTE

The optional power supply box (OT-BX88VII) is available. You can store the power supply unit in the box attached to the printer.

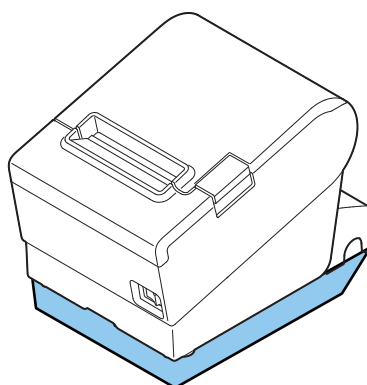

Connecting the Printer to the Host

CAUTION

- Be sure to install the driver before connecting the printer to the host computer.
- The printer uses modular connector specifically designed for the cash drawer. Do not connect this connector to an ordinary telephone line.

USB Interface

When using USB cable to connect with host device, connect the USB cable to the printer, and after starting the host device, turn the printer on.

CAUTION

- Do not place any weight or stress on the cable when using. Doing so could damage the cable and connectors.
- Make sure to use a USB 2.0 compliant cable.
- When the printer is connected to an Android device via USB, the connection may be disabled after changing the printer settings using TM Utility. In that case, restart TM Utility.

Ethernet Interface

Use ethernet cable to connect the printer to network via a hub.

Use TM-T88VII Utility (for Windows) to set network.

For details on TM-T88VII Utility (for Windows), refer to TM-T88VII Utility User's Manual.

CAUTION

- When LAN cables are installed outdoors, make sure they are connected through devices that have surge protection. Otherwise, the devices can be damaged by lightning.
- Never attempt to connect the drawer kick cable or a standard telephone line cable to the LAN connector.

NOTE

Like the conventional models, you can also use WebConfig. For details, see "[WebConfig](#)" on page 89.

Wireless LAN Interface (With OT-WL06)

You can connect using a wired cable (LAN/USB), or connect using SimpleAP mode, and setup a wireless LAN using a network configuration tool. When setting up multiple printers, you can connect using a wired cable (LAN/USB) and setup a wireless LAN using the Epson Deployment Tool.

Using Epson TM Utility (for iOS/Android), you can easily connect the printer to the network from an iOS or Android devices.

CAUTION

- When using wireless LAN, make sure you disconnect the LAN cable. If a LAN cable is connected, wireless LAN is disabled.
- When you set up the access point at the same time, set the access point in advance and check that it operates correctly.
- Examine the radio wave situation in the surrounding area before use.
- Avoid using the same channel that is used in the neighboring shops where Wireless LAN is used.
- Wireless LANs with a frequency band of 2.4 GHz interfere with *Bluetooth* communication. When using *Bluetooth* and Wi-Fi at the same time, we recommend using 5 GHz.
- When using the printer in environments where kitchen microwaves and other devices that may interfere radio waves are installed, observe the following points.
 - * Keep the printer away from the devices, such as kitchen microwaves, that may cause radio wave interference.
 - * Use channels that are away from the frequency bands that may cause radio wave interference.
 - * Place shields between the printer and the devices that may cause radio wave interference.
 - * Select either 2.4 GHz or 5 GHz, whichever is free from radio wave interference.
 - * In auto channel setting for the access point, do not select a channel in which the devices may cause radio wave interference.

NOTE

For SimpleAP mode, see "[Simple Setup for Wireless LAN](#)" on page 26.

Setting up from a Windows Computer using SimpleAP

Necessary Items

Prepare the following items.

- Computer for setting: Windows 11/10/8.1/8/7
Computer equipped with a wireless LAN function
- Utility for setting: TM-T88VII Utility (for Windows)

Follow the steps below to connect the printer.

1 Check that the Wireless LAN unit is connected to the printer.

2 Activate SimpleAP on the printer.

Check that SSID and QR code is printed. How to activate SimpleAP differs depending on whether network settings have been done or not.

When network settings have Not been done:

The printer activates SimpleAP when it is turned on.

NOTE

After starting the printer, check that the "SimpleAP Start" is printed. If nothing is printed after 70 seconds, you need to enable SimpleAP in interface settings mode.

When network settings have been done:

Activate SimpleAP from the setting menu available after printing the status sheet.

- 1) Print the status sheet. ["Printing a Status Sheet" on page 83](#)
- 2) Press the Feed button briefly (less than one second) three times.
"SimpleAP mode" is selected in the setting menu.
- 3) Hold down the Feed button for at least one second.
SimpleAP is activated.

3 Start TM-T88VII Utility (for Windows).

4 Connect the printer using SimpleAP.

Click [Add port] - [Network] - [Wi-Fi Direct (SimpleAP)], and then add the printer.

5 When the printer is connected, make the wireless LAN settings.

For information about the settings, see TM-T88VII Utility User's Manual.

Setting up Using a USB Connection from a Windows Computer

Necessary Items

Prepare the following items.

- Computer for setting: Windows 11/10/8.1/8/7
- Utility for setting: TM-T88VII Utility (for Windows)
- USB cable

Follow the steps below to connect the printer.

- 1 Connect the printer to a PC via the USB cable.**
- 2 Turn on the host computer.**
- 3 Turn on the printer.**
- 4 Start up the TM-T88VII Utility (for Windows).**

CAUTION

When TM-T88VII Utility (for Windows) starts, the Feed button is disabled.

- 5 Select the printer, and then press the [OK] button.**
If the printer is not displayed, press the "Add Port" button, and then add the printer connected by USB.
- 6 Perform network I/F as well as TCP/IP settings.**
For details on the settings, see the TM-T88VII Utility User's Manual.
- 7 When you have finished making settings, disconnect the USB cable, turn off the printer, and then turn it back on.**

Setting up from a Smart Device Using Epson TM Utility (for iOS/Android)

1 Confirm that the wireless LAN unit is connected to the printer.

2 Start the printer in SimpleAP mode.

NOTE

- Confirm that the SSID and QR code are printed.
- The method used to activate SimpleAP mode will depend on the status of the network settings.

When network settings are not set:

SimpleAP mode is automatically activated when the printer is turned on.

When network settings are set:

After a status sheet is printed, start from the setting menu.

1) Print a status sheet. (See "[Printing a Status Sheet](#)" on page 83.)

2) Press the Feed button briefly (less than one second) three times.

SimpleAP mode is selected in the setting menu.

3) Press and hold the Feed button (for at least one second).

SimpleAP mode is activated.

3 Start the Epson TM Utility (for iOS/Android).



4 Scan the QR code from the Epson TM Utility, and connect the printer using SimpleAP.

Scan the QR code from the QR code scanning screen in "Printer Selection".

1) Tap the model name at the upper part of the Home screen.

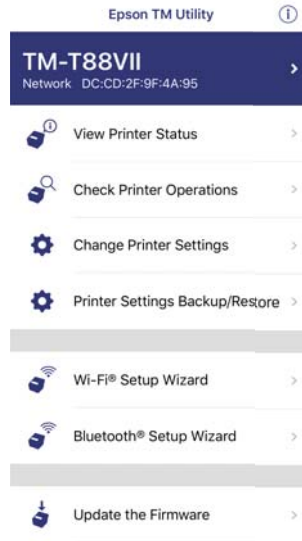

2) When you tap the center icon, the camera is activated.

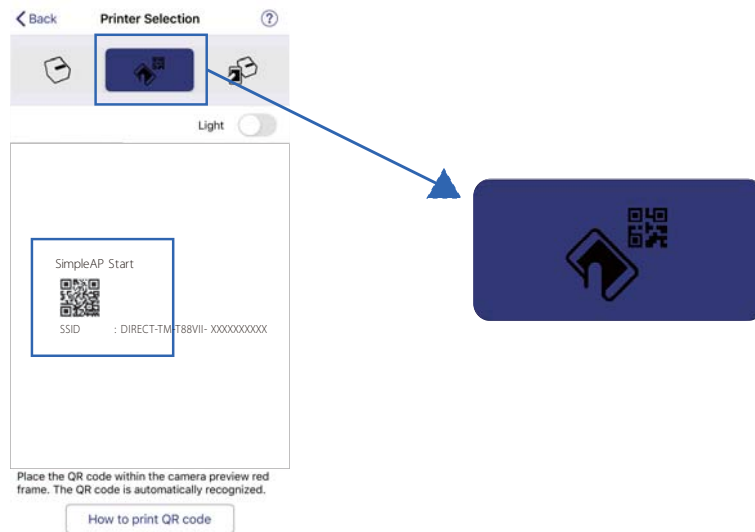

3) Scan the QR code on the status sheet.

5 When the printer is connected, configure the wireless LAN settings and make changes to other settings.

Serial Interface

When connecting to the host computer through a serial interface (RS-232), connect a serial cable to the printer, start the host computer, and then turn on the printer.

NOTE

- When using connectors equipped with screws, tighten the screws on both sides to secure the connectors firmly.
- When using interface cables equipped with a ground line, attach the ground line to the screw hole marked "FG" on the printer.

Parallel Interface

When connecting to the host computer using a parallel interface, connect the parallel cable to the printer, start the host computer, and then turn on the printer.

NOTE

When using interface cables equipped with a ground line, attach the ground line to the screw hole marked "FG" on the printer.

USB Plus Power Interface

When using a USB Plus Power cable to connect with the host device, connect the flat connector of the USB Plus Power cable to the printer, and the square connector to the device. After starting the host device, turn the printer on.

CAUTION

When using USB Plus Power Interface, be careful of the following points.

- Do not connect an AC adapter and USB (Type-B) simultaneously.
- Do not remove or insert the USB Plus Power cable while the printer is still on.

Connecting the Cash Drawer

CAUTION

- Do not connect both the optional external buzzer and the cash drawer to the printer at the same time by using a branched connector.
- When the optional external buzzer is enabled with the memory switch (customized values) (see ["Software Settings" on page 62](#)), a cash drawer cannot be used. Be sure to disable it when you use a cash drawer.
- Two driver transistors cannot be energized simultaneously.
- Leave intervals longer than 4 times the drawer driving pulse when sending it continuously.

Cash Drawer Requirements

Specifications of drawers differ depending on makers or models. When you use a drawer other than specified, make sure its specification meets the following conditions.

Otherwise, devices may be damaged.

- The load, such as a drawer kick solenoid, must be connected between pins 4 and 2 or pins 4 and 5 of the drawer kick connector.
- When the drawer open/close signal is used, a switch must be provided between drawer kick connector pins 3 and 6.
- The resistance of the load, such as a drawer kick solenoid, must be $24\ \Omega$ or more or the input current must be 1 A or less.
- Be sure to use the 24 V power output on drawer kick connector pin 4 for driving the equipment.

Drawer Connection Diagram

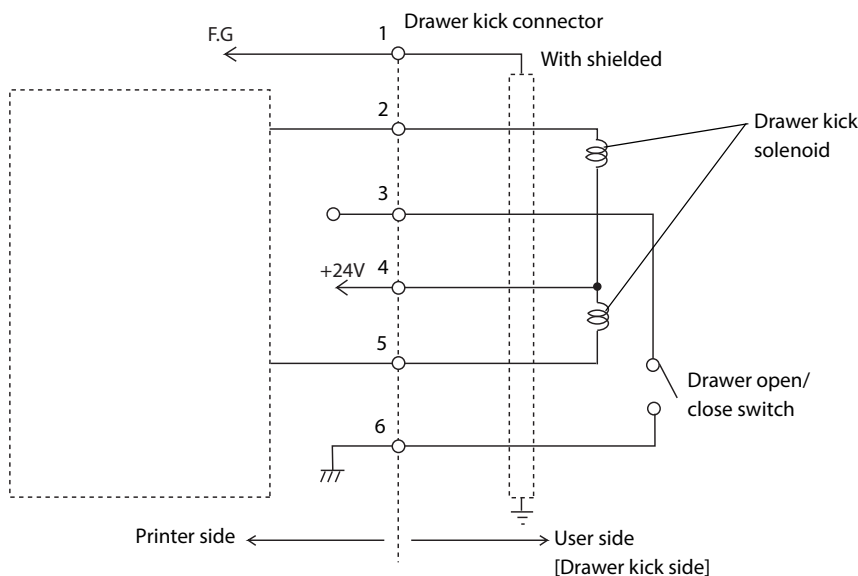

Adaptable Connector

RJ12 modular connector

Pin assignments

Pin number	Signal name	Direction
1	Frame GND	-
2	Drawer kick drive signal 1	Output
3	Drawer kick open/close signal	Input
4	+24 V	-
5	Drawer kick drive signal 2	Output
6	Signal GND	-

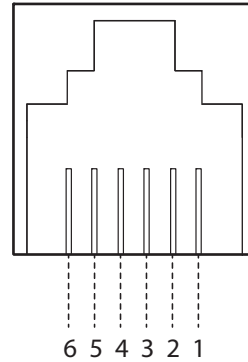

Connecting the drawer kick cable



- Use a shield cable for the drawer kick cable.
- When using cash drawer, make sure to use the power supply for printer (connector pins 4).
- Do not insert a telephone line into the drawer kick connector.
Doing so may damage the telephone line or printer.

Connect the drawer kick cable to the drawer kick connector by pressing firmly until the connector clicks into place.

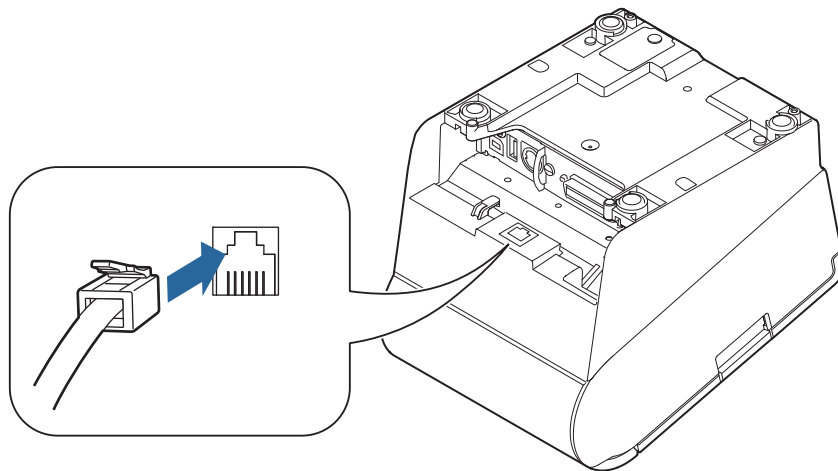

Setting the Built-in Buzzer (for Models with a Built-in Buzzer)

This printer outputs a pulse to pin 5 of the drawer kick connector to sound the built-in buzzer. When using a cash drawer, connect the cash drawer that is driven by pin 2.

If you have no choice but to use a cash drawer that is driven by pin 5, change the pin number of the built-in buzzer to a pin that does not conflict with the pin used by the cash drawer.

CAUTION

If you are using an Epson cash drawer, there is no need to alter the settings.

Using Epson TM Utility

- 1 **Select built-in buzzer.**
[Change Printer Settings] - [Various Settings] - [Buzzer] - [Select buzzer] - [Internal Buzzer]
- 2 **Enable the PIN number of the built-in buzzer.**
 - Set the PIN number that drives the cash drawer to [Off].
 - Set the PIN number that does not drive the cash drawer to [Once] if you want the buzzer to sound, or to [Off] if you do not want the buzzer to sound.

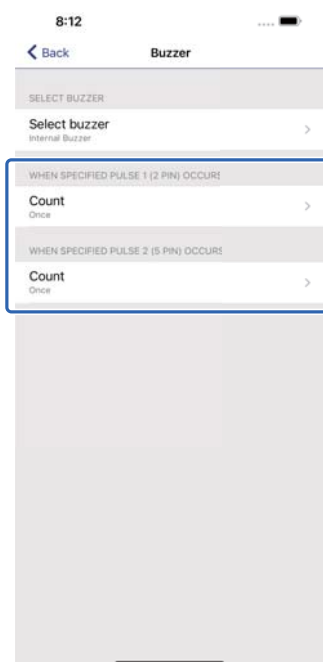

NOTE

Do not set both [WHEN SPECIFIED PULSE 1 (2 PIN) OCCURS] and [WHEN SPECIFIED PULSE 2 (5 PIN) OCCURS] to [Once]. Otherwise, the built-in buzzer will not work properly.

Using TM-T88VII Utility

1 Select built-in buzzer.

[Main] - [Detailed Settings] - [Buzzer] - [Internal Buzzer]

2 Enable the PIN number of the built-in buzzer.

- Set the PIN number that drives the cash drawer to [Off].
- Set the PIN number that does not drive the cash drawer to [Once] if you want the buzzer to sound, or to [Off] if you do not want the buzzer to sound.

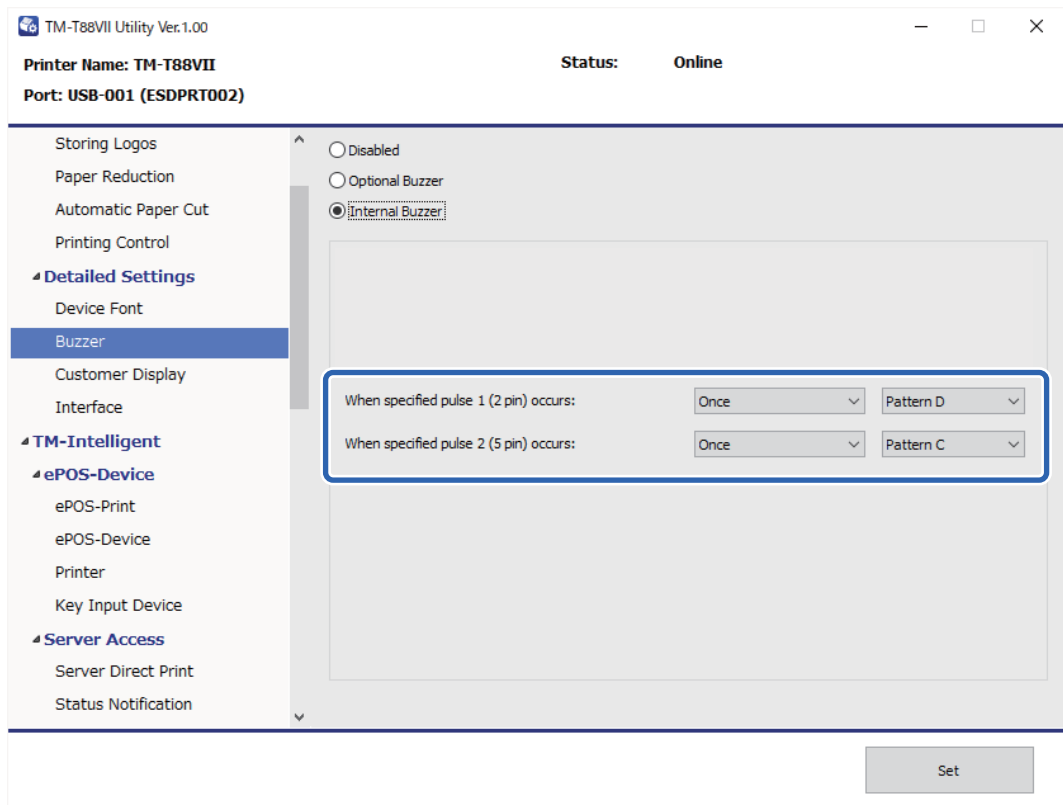

For details on TM-T88VII Utility (for Windows), refer to the TM-T88VII Utility User's Manual.

Connecting the Optional External Buzzer

When the optional external buzzer (model: OT-BZ20) is connected to the drawer kick connector of the printer, you can set the printer so that it beeps when you send commands, when an error occurs, when executed autocutting, and when detected paper end. Settings for sound patterns and frequency depending on the occasions the buzzer beeps are also available.

You need to set with the memory switch (customized values) for buzzer enable/disable setting, sound pattern setting, and frequency setting. For information about the memory switch (customized values), see ["Software Settings" on page 62](#).

CAUTION

- Be sure to turn off the printer before you connect/disconnect the optional external buzzer.
- Do not connect both the optional external buzzer and the cash drawer to the printer at the same time by using a branched connector.

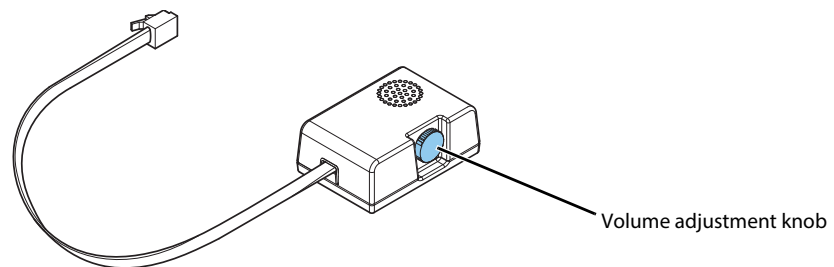

Attachment Position

The optional external buzzer is recommended to be installed in the following positions.

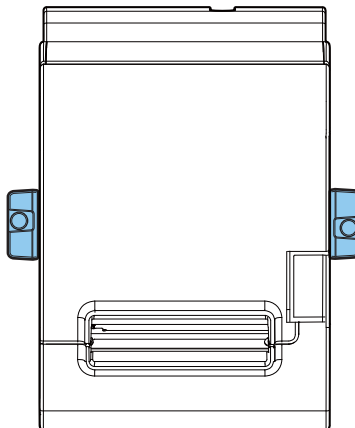

CAUTION

- Do not install the optional external buzzer at the roll paper exit.
- To prevent liquid from entering inside, it is recommended to install the optional external buzzer so that the volume adjustment knob is positioned sideways or downward.

Connecting the Optional Wireless LAN Unit

The optional Wireless LAN cable set (OT-WL06) enables you to use the product with a Wi-Fi connection. For more information, refer to Technical Reference Guide of the Wireless LAN cable set.

CAUTION

- Be sure to turn off the printer when connecting the Wireless LAN unit.
- Depending on the installation conditions of the printer and the routing for cables connected to it, the status of the radio waves for the Wireless LAN unit may decline. If this does happen, use an extension cable.
- Do not disconnect the Wireless LAN unit from the printer while the printer is powered.

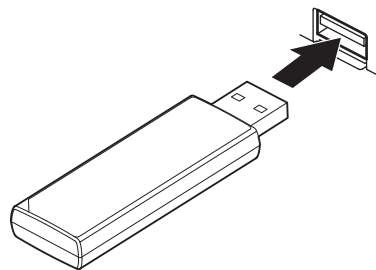

Connecting the Optional Customer Display

You can connect the customer display (DM-D30/DM-D70/DM-D110/DM-D210) to this product, using USB connection.

For more information, refer to the Technical Reference Guide of the customer display.

CAUTION

- Be sure to turn off the printer when connecting the customer display.
- All modes are usable only with a Fixed Interface model (Standard mode/Fixed column and row mode).
- When connecting this product to the DM-D70 that came with ferrite core, it is necessary to attach the ferrite core to the USB cable of the DM-D70. For more information, refer to DM-D70 Technical Reference Guide.

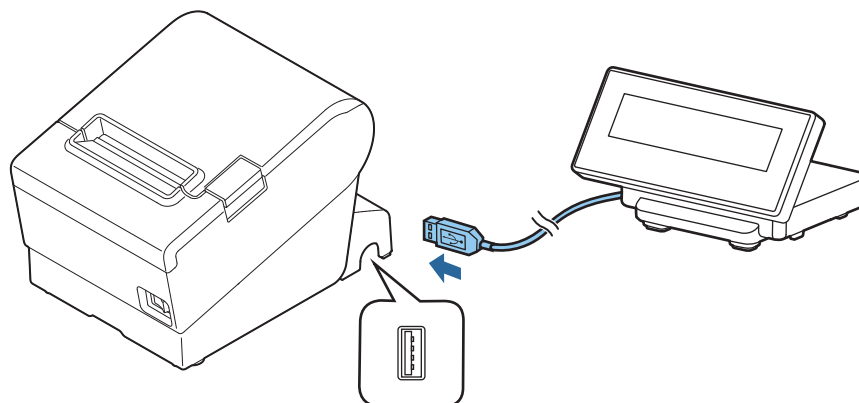

Attaching the Connector Cover

When using the connector cover, attach the connector cover.
Follow the steps below to attach the connector cover to protect cables.

- 1** Turn over the printer.
- 2** Position the two hooks on both sides of the connector cover so that they hook the printer case.

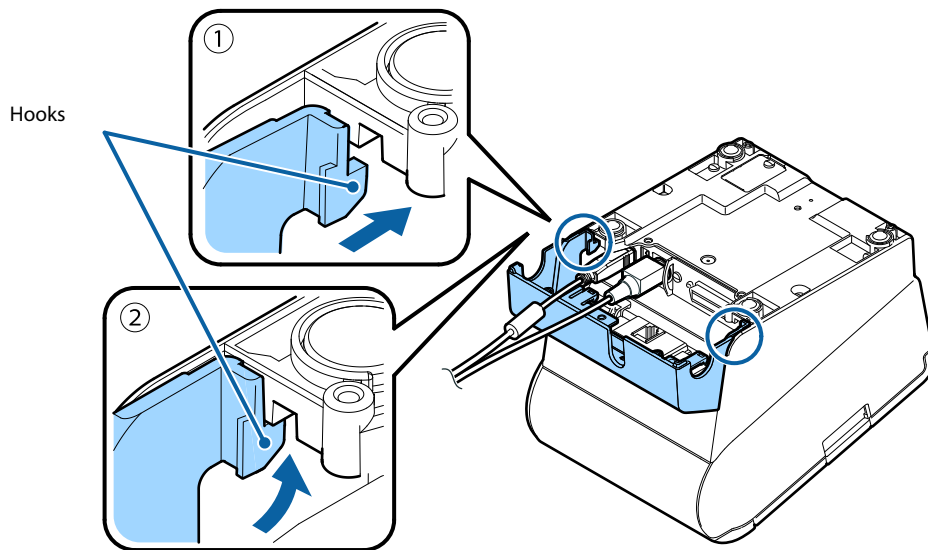

- 3** Push the connector cover down to click onto the printer case.

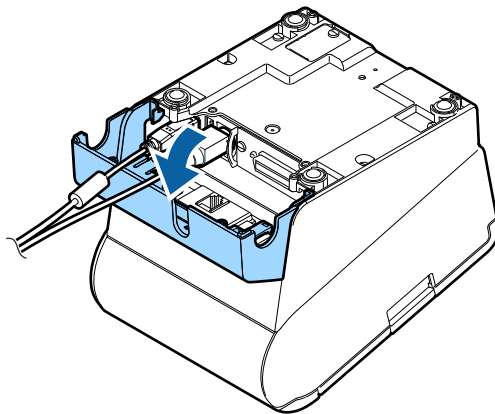

NOTE

- You can use the enclosed screw to fix the connector cover.

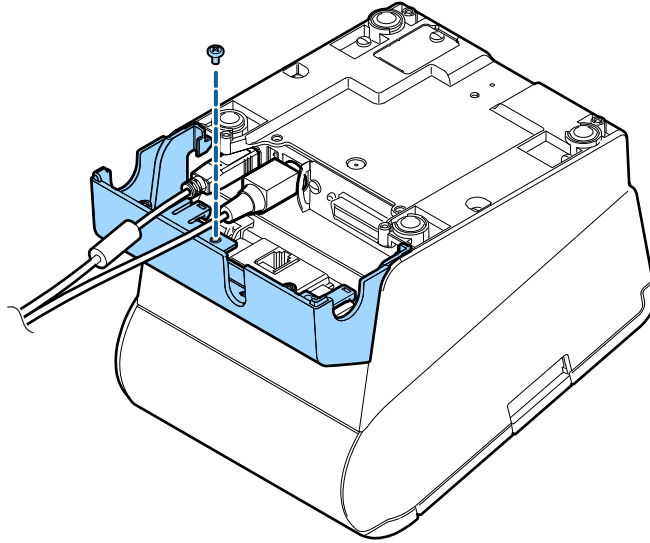

- To remove the connector cover, turn the printer over, remove the screw, and push the connector cover down while pushing both sides of the connector cover inward to detach the hooks from the printer case.

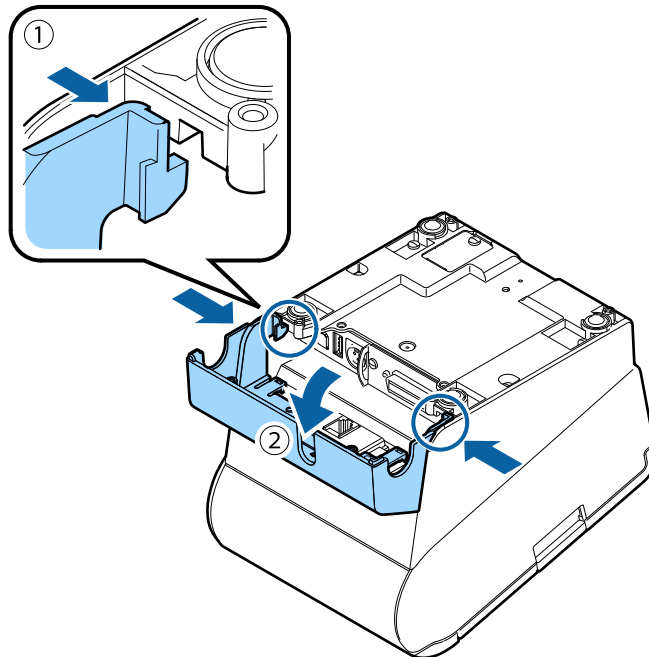

Arranging the Cables

Route the cables when using the connector cover.

Pass the cables through cable exits in the connector cover. The connector cover has cable exits on the back and both sides.

You can also route the cables out the front by passing them through the notch in the printer bottom.

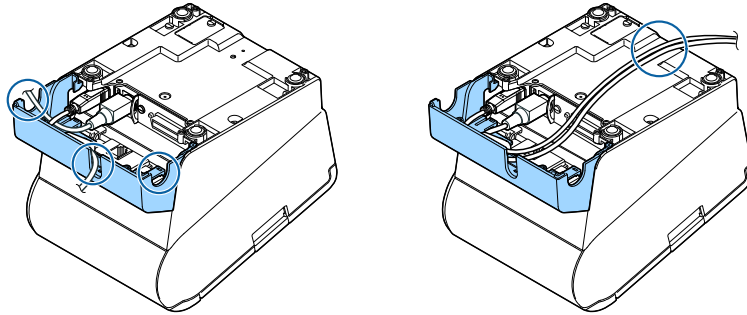

If you want to pass the USB cable through the cable exit on the back, fit the cable under the hook on the printer to prevent the cable from coming off and to prevent too much force being applied to the connector section.

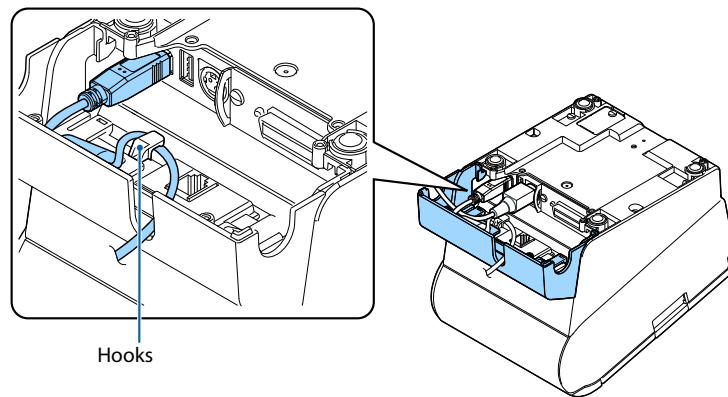

NOTE

- When using an unlocked cable with Fixed interface model, use of the bundled cable lock band is recommended.

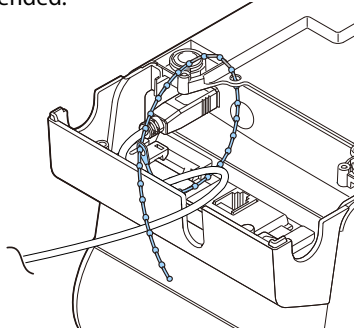

- You can also attach bottom cover to hide connectors. Make sure the cable does not get caught when installing.

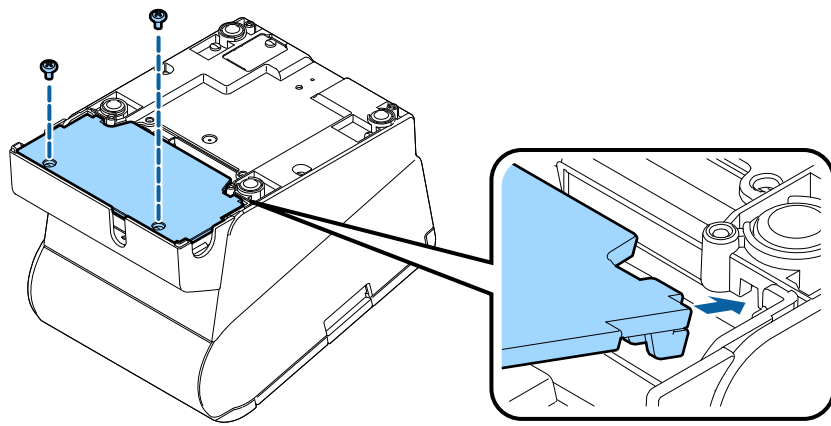

After the cable arrangement, turn over the printer, and make sure the cables are not pinched.

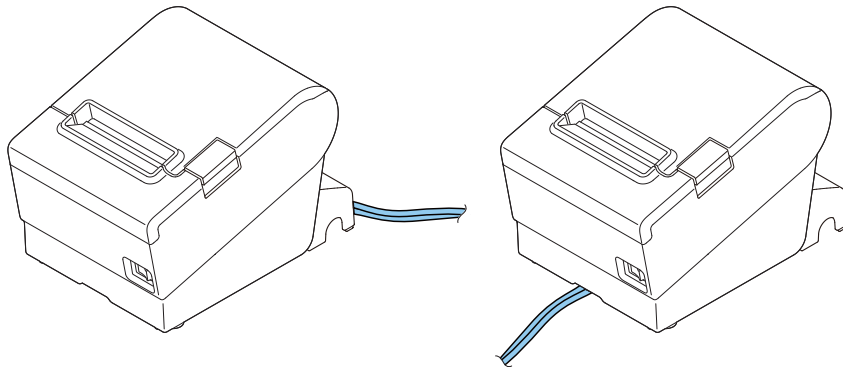

Attaching the Power Switch Cover

By attaching the power switch cover supplied, you can prevent accidental operations of the power switch. You can press the power switch by inserting a sharp-pointed object in the holes on the power switch cover. To detach the cover, use a sharp-pointed object.

**WARNING**

If an accident occurs with the power switch cover attached, unplug the power cord immediately. Continued use may cause fire or shock.

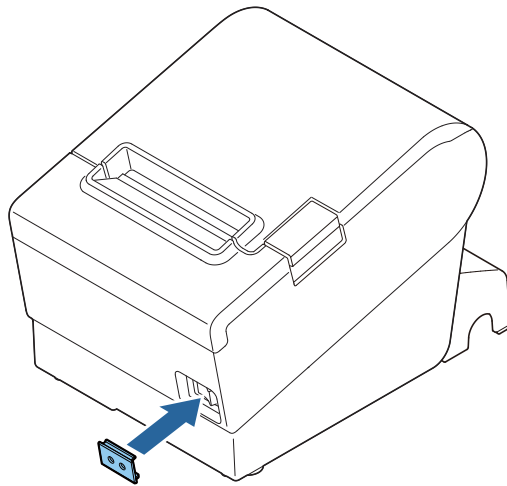

Changing the Paper Width

You can change the paper width from 80 to 58 mm by installing the included 58 mm width roll paper guide. Follow the steps below to change the paper width.

CAUTION

Once you change the paper width to 58 mm and print on 58 mm width roll paper, you cannot go back to 80 mm width. Because parts of the print head that do not normally touch the paper may be damaged by the platen roller, and the autocutter may wear out.

- 1 Make sure the printer is turned off.
- 2 Open the roll paper cover.

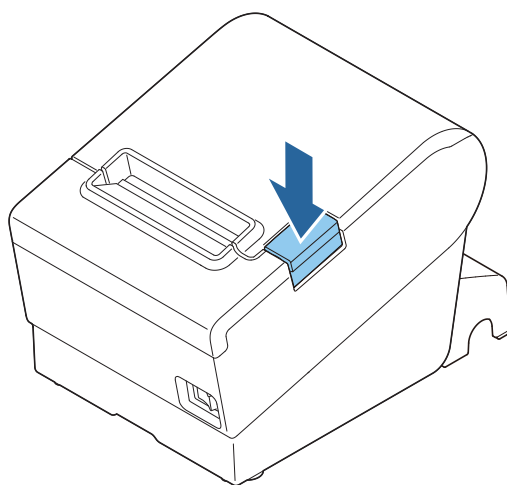

- 3 Install the roll paper guide so that the protrusion on the roll paper holder is aligned with the hole on the printer.

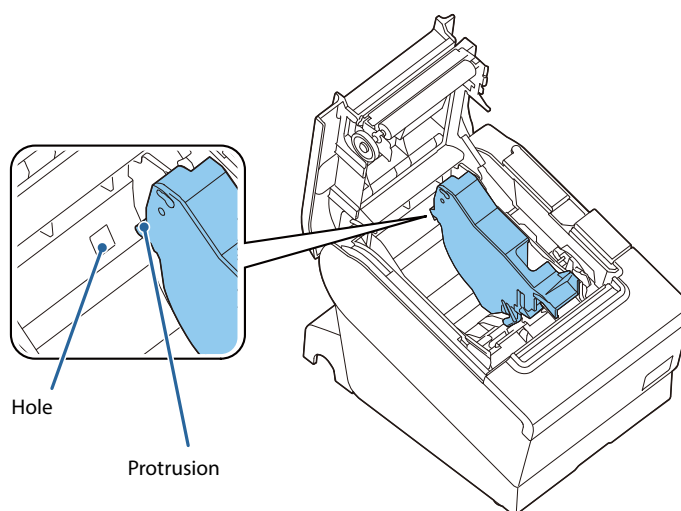
**NOTE**

You can use the enclosed screw to fix the roll paper guide.

- 4 Set the paper width in software setting mode.
For information about the software setting mode, see ["Software Settings" on page 62](#).

RTC Settings

The time for the RTC (Real Time Clock) may be initialized when starting up for the first time. If the time is initialized, make settings using the Setup Utilities.

For details on making settings using the Setup Utilities, see the TM-T88VII Utility User's Manual.

Advanced Usage

Setting the DIP Switches

On this printer, you can make various settings with DIP switches. The DIP switches are already set for the current interfaces. Change the setting if necessary. Functions of the DIP switches differ depending on the interface.

Setting Procedure

Follow the steps below to change the DIP switch settings.



- **Before you remove the DIP switch cover, turn off the printer and disconnect all cables.** Otherwise, a short-circuit may cause the printer to malfunction.
- **If you open the DIP switch cover, be sure to close the cover and tighten the screw after adjusting the DIP switch.** Using this product with the cover open may cause fire or electric shock.

CAUTION

- DIP switch settings are enabled only when the power is turned on or the printer is reset via the interface. If the settings are changed after that, the functions will not change.
- Do not change switches that are fixed to ON or OFF. Otherwise, the printer may not operate normally.

- 1 Make sure the printer is turned off.**
- 2 Unscrew the screw to remove the DIP switch cover from the base of the printer.**

Fixed Interface model has DSW1 only.

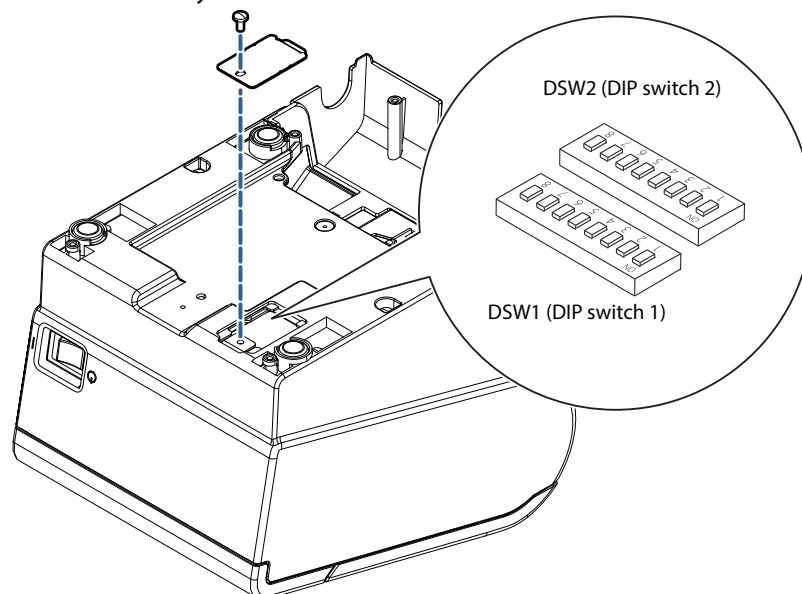

- 3** Set the DIP switches, using the tip of a tool, such as a small screwdriver.
- 4** Replace the DIP switch cover, and screw it in place.

Serial Model

DIP Switch Bank 1

SW	Function	ON	OFF	Default setting
1-1	Data reception error	Ignored	Prints "?"	OFF
1-2	Reserved (Do not change the setting)	Fixed to OFF		OFF
1-3	Handshaking	XON/XOFF	DTR/DSR	OFF
1-4	Word length	7 bits	8 bits	OFF
1-5	Parity check	Yes	No	OFF
1-6	Parity selection	Even	Odd	OFF
1-7	Baud rate selections	See the " Transmission Speed (DIP Switches 1-7/1-8) " table below.		ON
1-8				OFF

Transmission Speed (DIP Switches 1-7/1-8)

Transmission speed (bps: bits per second)	SW 1-7	SW 1-8
Depends on the software setting mode settings.*	ON	ON
4800	OFF	ON
9600 (default)	ON	OFF
19200	OFF	OFF

bps: bits per second

* The default value of transmission speed set with software settings is 38400 bps. (See "[Software Settings](#)" on [page 62](#).)

NOTE

Depending on print conditions, such as print duty, print head temperature, and data transmission speed, print speed is automatically adjusted, which can cause white lines due to intermittent print (the motor sometimes stops). To avoid this, set the transmission speed higher or keep the print speed constant by setting it lower.

DIP Switch Bank 2

SW	Function	ON	OFF	Default setting
2-1	Handshaking (BUSY condition)	Receive buffer full	Offline or Receive buffer full	OFF
2-2	Reserved (Do not change setting)	Fixed to OFF		OFF
2-3	Selects print density	See the " Selecting the Print Density (DIP Switches 2-3/2-4) " table below.		OFF
2-4				
2-5	Reserved (Do not change setting)	Fixed to OFF		OFF
2-6	Reserved (Do not change setting)	Fixed to OFF		OFF
2-7	I/F pin 6 reset signal	Enabled	Disabled	OFF
2-8	IF pin 25 reset signal	Enabled	Disabled	OFF

CAUTION

- For DIP Switch 2-1 (BUSY condition), see also "[Selecting the BUSY Status](#)" on page 61.
- When you use the APD, change the setting of DIP switch 2-1 (BUSY condition) to ON.

Selecting the Print Density (DIP Switches 2-3/2-4)

Function	SW 2-3	SW 2-4
Do not set	ON	ON
Print density (light)	OFF	OFF
Print density (medium)	ON	OFF
Print density (dark)	OFF	ON

CAUTION

- If the print density is set to "Medium" or "Dark" level, print speed may be reduced.
- The print density can be set with DIP switches (2-3/2-4) or the software settings. (See "[Software Settings](#)" on page 62.)

Parallel Model/Powered USB Model

DIP Switch Bank 1

SW	Function	ON	OFF	Default setting
1-1	Auto line feed	Always enabled	Always disabled	OFF
1-2	Reserved (Do not change the setting)	Fixed to OFF		OFF
1-3	Selects paper sensors to output paper-end signals (default value of a command)* ¹	Disabled	Roll paper end sensor enabled, roll paper near-end sensor enabled	OFF
1-4	Error signal output* ¹	Disabled	Enabled	OFF
1-5	Undefined	—		OFF
1-6				
1-7				
1-8				

*1: For Parallel model only.

DIP Switch Bank 2

SW	Function	ON	OFF	Default setting
2-1	Handshaking (BUSY condition)	Receive buffer full	Offline or Receive buffer full	OFF
2-2	Reserved (Do not change setting)	Fixed to OFF		OFF
2-3	Selects print density	See the " Selecting the Print Density (DIP Switches 2-3/2-4) " table below.		OFF
2-4				
2-5	Reserved (Do not change setting)	Fixed to OFF		OFF
2-6	Reserved (Do not change settings)	Fixed to OFF		OFF
2-7	Reserved (Do not change settings)	Fixed to OFF		OFF
2-8	If pin 31 reset signal* ¹	Fixed to ON		ON
	Reserved (Do not change settings)* ²	Fixed to OFF		OFF

*1: For Parallel model only.

*2: For Powered USB model only.

CAUTION

For DIP Switch 2-1 (BUSY condition), see also "[Selecting the BUSY Status](#)" on page 61.

Selecting the Print Density (DIP Switches 2-3/2-4)

Function	SW 2-3	SW 2-4
Do not set	ON	ON
Print density (light)	OFF	OFF
Print density (medium)	ON	OFF
Print density (dark)	OFF	ON

CAUTION

- If the print density is set to “Medium” or “Dark” level, print speed may be reduced.
- The print density can be set with DIP switches (2-3/2-4) or the software settings. (See ["Software Settings" on page 62.](#))

Fixed Interface Model

DIP Switch Bank

SW	Function	ON	OFF	Default setting
1	Handshaking (BUSY condition)	Receive buffer full	Offline or Receive buffer full	OFF
2	Reserved (Do not change setting)	Fixed to OFF		OFF
3	Selects print density	See the " Selecting the Print Density (DIP Switches 3/4) " table below.		OFF
4				
5	Reserved (Do not change setting)	Fixed to OFF		OFF
6	Reserved (Do not change settings)	Fixed to OFF		OFF
7	Reserved (Do not change settings)	Fixed to OFF		OFF
8	Reserved (Do not change settings)	Fixed to OFF		OFF

CAUTION

For DIP Switch 1 (BUSY condition), see also "[Selecting the BUSY Status](#)" on page 61.

Selecting the Print Density (DIP Switches 3/4)

Function	SW 3	SW 4
Do not set	ON	ON
Print density (light)	OFF	OFF
Print density (medium)	ON	OFF
Print density (dark)	OFF	ON

CAUTION

- If the print density is set to "Medium" or "Dark" level, print speed may be reduced.
- The print density can be set with DIP switches (3/4) or the software settings. (See "[Software Settings](#)" on page 62.)

Selecting the BUSY Status

With DIP switch 2-1, you can select conditions for invoking a BUSY state as either of the following:

- When the receive buffer is full
- When the receive buffer is full or the printer is offline

CAUTION

In either case above, the printer enters the BUSY state after power is turned on (including resetting with the interface) and when a self-test is being run.

Printer BUSY Condition and Status of DIP Switch 2-1

Printer status		DIP SW 2-1	
		ON	OFF
Offline	During the period after power is turned on (including resetting with the interface) to when the printer is ready to receive data.	BUSY	BUSY
	During the self-test.	BUSY	BUSY
	When the cover is open.	—	BUSY
	During paper feed with the Feed button.	—	BUSY
	When the printer stops printing due to a paper-end (when printer has run out of roll paper).	—	BUSY
	When a macro is executed and waiting for the power is turned on.	—	BUSY
	When an error has occurred.	—	BUSY
When the receive buffer becomes full.		BUSY	BUSY

Software Settings

With the memory switches and customized values, which are software settings for this printer, you can set the various functions.

For an outline of the functions, see the following section. Use the methods shown in the table below, or ESC/POS commands for the settings.

NOTE

- The software setting mode is the mode set using the printer's panel. For details on panel operations, see "[Software Setting Mode \(Customize Value Settings\)](#)" on page 77.
- For details about the items that can be set with ESC/POS commands and the setting method, see the ESC/POS command reference.
- If the same setting is set using the DIP switch, the DIP switch setting is applied.

Item/Method	Software Setting Mode	TM-T88VII Utility (for Windows)	Epson TM Utility (for iOS/Android)
Print Density	✓	✓	✓
Print Speed	✓	✓	✓
Automatic Paper Reduction	✓	✓	✓
Auto Paper Feed&Cut at cover close	✓	✓	✓
Paper Width	✓	✓	✓
Top Margin	✓	✓	✓
Character/Font Settings	✓	✓ ^{*1}	✓ ^{*1}
Interface Selection	✓		
Interface Settings	✓	✓	✓
Intelligent Settings	✓		
Command Execution (Offline)	✓	✓	✓
Power Supply Output	✓	✓	✓
Other Settings	✓	✓ ^{*2}	✓ ^{*2}
Cut Error Release Method		✓	✓
Logo		✓	✓
ePOS-Print		✓	✓
ProxyInfo		✓	✓
Server Direct Print		✓	✓
Status Notification		✓	✓
Customer Display		✓	✓
Network CS Authentication		✓	✓
Network Dev Info		✓	✓
Ethernet Config		✓	✓

Item/Method	Software Setting Mode	TM-T88VII Utility (for Windows)	Epson TM Utility (for iOS/Android)
Wi-Fi Config		✓	✓
SSL/TLS Config		✓	✓ ^{*4}
Certificate Config		✓	✓ ^{*4}
TCP/IP Config		✓	✓
SNMP Config		✓	✓
Time Config		✓	✓
LPR Config		✓	✓
Port9100 Config		✓	✓
IP/Port Filter Config		✓	✓

*1: Except for "Thai Character Composition" and "Embedded Font Replacement".

*2: Only "Buzzer Control" can be set.

*3: Can be set on WebConfig that can be accessed from the Epson TM Utility.

Functions

Print Density

Monochrome

Selectable from 70 to 130% (5% increment)

Default setting: 100%

Depending on the paper type, it is recommended to set the print density as shown in the table below for the best print quality.

Original Paper type	Density	Print speed
AP50KS-ND	100%	17 (500 mm/sec)
KT55FA, AP45KS-ND	100%	16 (450 mm/sec)
KT48FA, KT55PF	100%	15 (400 mm/sec)
KT48PF, P5047(55), P5047(46)	105%	15 (400 mm/sec)

NOTE

- When the print density level is increased, print speed may be reduced. When printing at a density of 115% or more and below a room temperature of 15°C, the speed drops to less than 200 mm/sec.
- When setting the print speed to level 17, use customized values to set the print density.
- With monochrome printing, two-stage printing is available.

Multi-Tone

Selectable from 70 to 130% (5% increment)

Default setting: 100%

NOTE

- With multi-tone printing, 16-stage printing is available.
- Set the monochrome print density first before setting the multi-tone print density.

Print Speed

- High Speed (500 mm/s)
- Standard Speed (450 mm/s) (default setting)
- Middle Speed (350 mm/s)

*Default setting: Varies by country/region where the printer is purchased

CAUTION

- The print speed is restricted according to the Number of head energizing parts setting. The maximum 500 mm/s is possible with the One-part energizing (default) option. The Number of head energizing parts setting can be changed using ESC/POS commands. ("[ESC/POS](#)" on page 91)
- The maximum printing speed when using 58 mm is 450 mm/s.

NOTE

- When setting the print speed to [High Speed], set the print density using Customized Value Setting.
- Depending on print conditions, such as print duty, print head temperature, and data transmission speed, print speed is automatically adjusted, which may cause white lines due to intermittent print (the motor sometimes stops). To avoid this, keep the print speed constant by setting it lower.
- By using a setting tool such as TM-T88VII Utility, the print speed can be selected from 17 levels (from the slowest level 1 to the fastest level 17). (Default setting: level 16)

Automatic Paper Reduction

Upper Margin

- Enable
- Disable (default setting)

Lower Margin

- Enable
- Disable (default setting)

Blank Line Spacing

- 25%
- 50%
- 75%
- Not Reduce (default setting)

Blank Space

- 25%
- 50%
- 75%
- Not Reduce (default setting)

Barcode Height

- 25%
- 50%
- 75%
- Not Reduce (default setting)

Character Height

- Inner Spacing
- Inner Spacing & Height
- Not Reduce (default setting)

NOTE

- No reduction is applied to blank dot lines that exist in a graphic data.
- Reduced barcodes are not guaranteed to be correctly scanned. Make sure to check whether they are properly read by a barcode reader that is actually used.

Auto Paper Feed&Cut at cover close

- Enable
- Disable (default setting)

Paper Width

- 80 mm (default setting)
- 58 mm

Top Margin

Selectable from levels 15 ~ 2 mm (0.5 mm interval)

Default setting: level 15 mm

CAUTION

- Remove all ejected paper before printing with backfeed.
- Disable the automatic top logo setting when enabling backfeed.
- You cannot use backfeed in the following cases even if you have enabled backfeed.
 - * Immediately after auto cutting while the cover is closed.
 - * While the self-test is in progress.
- If setting a top margin of 5 mm {0.2"} or less, confirm that no errors occur in your environment of usage. Usage in a hot and humid environment or usage of paper that curls easily may increase the risk of paper jams.
- When implementing a backfeed, rubbing smears may occur due to slack in the paper. We recommend using thermal paper with high rub resistance.

Character/Font Settings

Default Character Code Page

Selectable from 43 pages including user defined page

Initial setting: PC437: USA, Standard Europe

Default International Character Set

Selectable from 18 sets

Initial setting: USA

Thai Character Composition

- 3 pass
- 1 pass (default setting)

Embedded Font Replacement

Font A Replacement

- Does not replace (default setting)
- Font B
- Special Font A
- Special Font B

Font B Replacement

- Does not replace (default setting)
- Font A
- Special Font A
- Special Font B

Multi-Language Font

- Thai, Vietnam (default setting)
- Simplified Chinese

Font Priority

- ANK
- Japanese (default setting)
- Simplified Chinese
- Traditional Chinese
- Korean

Interface Selection

- UIB (Serial, Parallel, and Power Plus USB models only)
- Built-in USB
- Ethernet/Wi-Fi
- Auto (Only the UIB or the built-in USB which first established communication after the power is turned on can be used.)
- Multiple (All interfaces are enabled.) (default setting)

NOTE

- Auto: After the power is turned on, the first interface that establishes communication, either the UIB or the built-in USB, is automatically selected. Other interfaces are disabled. This selection remains valid until the power is turned off or the printer is reset.
- Multiple: The first interface to make communication after the power is turned on becomes the main connection, and other interfaces can be used as secondary connections.

Interface Settings

Serial Interface Baud Rate

- 2400 bps
- 4800 bps

- 9600 bps
- 19200 bps
- 38400 bps (default setting)
- 57600 bps
- 115200 bps

USB Interface Settings

Class

- Vendor Class (default setting)
- Printer Class

IEEE1284 Device ID

- Do not output IEEE1284 Device ID
- Output IEEE1284 Device ID (default setting)

USB power-saving function

- Enable
- Disable (default setting)

CAUTION

Enabled when anything other than the UB-U06 is installed to the UIB.

NOTE

- The Class setting is applied only to the USB Type B connector.
- The USB power-saving function is valid only when the USB interface communication condition is set to the vendor-defined class and the system configuration is set so that the USB driver can support the USB power-saving function.

Interface switch waiting time

Select the number of seconds from 1 to 10 in increments of 1 second, or 60 seconds.

Default setting: 10 seconds

Main connection interface

- UIB
- Built-in USB
- Ethernet/Wi-Fi
- Auto (default setting)
- No main connection I/F

CAUTION

- When using this printer with multiple interfaces, make sure the interface that is always connected to be set as the main connection.
- You cannot use wired LAN and wireless LAN at the same time.

The "Auto" setting allows you to use the first interface you communicate with as the main connection and the other interfaces as secondary connections after you turn on the printer. For the limitations on the main connection and secondary connections, see the table below.

Connection Interface	Connection Priority	ESC/POS Command Limitations	Retaining of Print Settings When Connection Is Terminated
Main connection	High	No	Retained
Secondary connection	Low	Yes*	Initialized

*For details, see the ESC/POS Command Reference.

NOTE

- The displayed items vary depending on the interface configuration.
- For information about the function, see ["Printing Using Multiple Interfaces" on page 28.](#)

Auto Line Feed

- Always disabled (default setting)
- Always enabled

CAUTION

This is only enabled when using a serial interface. When using another interface, make settings by using the DIP switches.

Output Paper-end Signals

- Enable (default setting)
- Disable

CAUTION

When using a parallel interface, make settings by using the DIP switches.

Error Signal Output

- Enable (default setting)
- Disable

CAUTION

When using a parallel interface, make settings by using the DIP switches.

Intelligent Settings

Print Data Parsing

- Enable
- Disable (default setting)

NOTE

The setting item may not be available depending on the region.

Command Execution (Offline)

- Enable
- Disable (default setting)

Power Supply Output

Selectable from levels 1 to 3 low power load

Default setting: level 3

Other Settings

Printer Model

- TM-T88VII (default setting)
- TM-T88V
- TM-T88VI

Column Emulation

- 42/30 Column mode (default setting)
- 48/36 Column mode

NOTE

This function is supported only on the ANK model.

NV Capacity

User NV Memory

- 1 KB (default setting)
- 64 KB
- 128 KB
- 192 KB

NV Graphics Memory

- 256 KB (default setting)
- 320 KB
- 384 KB

Buzzer Control

NOTE

- For information about how to connect the optional external buzzer, see "[Connecting the Optional External Buzzer](#)" on page 45.
- When the optional external buzzer is enabled, a cash drawer cannot be used. Be sure to disable it when you use a cash drawer.

Option Buzzer (model: OT-BZ20)

- Enable
- Disable (default setting)

Buzzer Frequency (Error)

- Continuous (default setting)
- 1 time
- No sound

Sound Pattern (Autocut)

Selectable from Patterns A to E

Default setting: Pattern A

Buzzer Frequency (Autocut)

- 1 time (default setting)
- No sound

Sound Pattern (Pulse 1)

Selectable from Patterns A to E

Default setting: Pattern A

Buzzer Frequency (Pulse 1)

- 1 time (default setting)
- No sound

Sound Pattern (Pulse 2)

Selectable from Patterns A to E

Default setting: Pattern B

Buzzer Frequency (Pulse 2)

- 1 time (default setting)
- No sound

Setting/Checking Modes

As well as print mode, the following modes are also provided for making various printer settings and checking items.

- Self-test mode
- NV graphics information print mode
- Receipt Enhancement information print mode
- Software settings mode
- Restore default values mode
- Interface setup mode
- TM-Intelligent settings information print mode
- Hexadecimal dumping mode

The self-test mode or hexadecimal dumping mode is selected depending on the operation performed when the power is turned on.

NV graphic information print mode, Receipt Enhancement information print mode, Software settings mode, and Restore default settings mode are selected depending on the Feed button operation performed during a self-test.

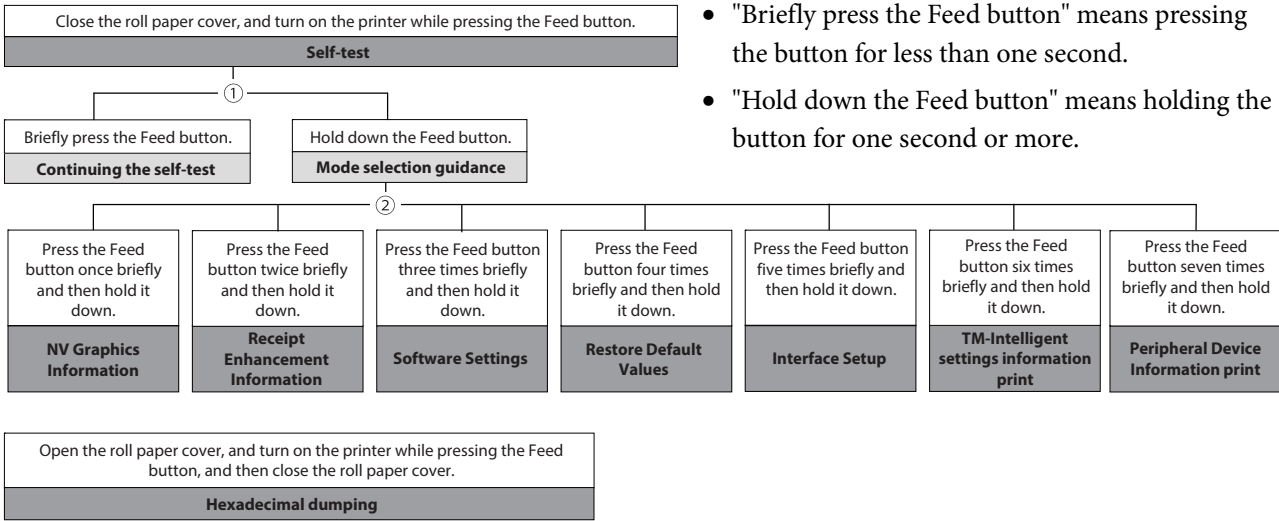

- "Briefly press the Feed button" means pressing the button for less than one second.
- "Hold down the Feed button" means holding the button for one second or more.

In 1 and 2, the following guidances are printed, the Paper LED flashes, and instructs the user's operations.

1. Continuing self-test guidance

Select Modes by pressing Feed Button.
Continue SELF-TEST: Less than 1 second
Mode Selection : 1 second or more

2. Mode selection guidance

Mode Selection

Modes

- 0: Exit and Reboot Printer
- 1: NV Graphics Information
- 2: Receipt Enhancement Information
- 3: Customize Value Settings
- 4: Restore Default Values
- 5: Interface Setup
- 6: TM-Intelligent Information
- 7: Peripheral Device Information
- 8 or more: None

Select Modes by executing following procedure.

- step 1. Press the Feed button less than 1 second as many times as the selected mode number.
- step 2. Press Feed button for 1 second or more.

Self-test Mode

You can check the following items using the self-test.

- Product name
- Firmware version
- Product serial number
- Interface type
- Resident fonts
- Maintenance counter information (head running length, number of times of autocutting)
- Setting condition of the DIP switch

Follow the steps below. You can also run the self-test using the ESC/POS commands.

- 1 Close the roll paper cover.**
- 2 While pressing the Feed button, turn on the printer. (Hold down the Feed button until printing starts.)**
After printing the current print status, a Continuing self-test guidance is printed, and the Power LED flashes.
- 3 Briefly press the Feed button (less than one second) to continue the self-test.**
The printer prints a rolling pattern on the roll paper, using the built-in character set.
After "*** completed ***" is printed, the printer initializes and switches to standard mode.

NV Graphics Information Print Mode (NV Graphics Information)

Prints the following NV graphic information registered to the printer.

- Capacity of the NV graphics
- Used capacity of the NV graphics
- Unused capacity of the NV graphics
- Number of NV graphics that are registered
- Key code, number of dots in X direction, number of dots in Y direction to be defined.
- NV graphics data



For details on NV graphics, see ["NV Graphics Memory" on page 24](#).

Follow the steps below.

1 After running a self-test, hold down the Feed button for at least one second, and then select the Mode selection.

The Mode selection guidance is printed, and the Paper LED flashes.

2 After briefly (less than one second) pressing the Feed button once, hold it down for at least one second, to print the NV graphics information.

After information printing, the Mode selection guidance is printed again.

3 To finish, turn off the power, or select "Exit and Reboot Printer".

Receipt Enhancement Information Print Mode (Receipt Enhancement Information)

You can check the following items using the R/E information mode:

- Automatic top logo setting
- Automatic bottom logo setting
- Extended settings for automatic top/bottom logo

Follow the steps below.

1 After running a self-test, hold down the Feed button for at least one second, and then select the Mode selection.

The Mode selection guidance is printed, and the Power LED flashes.

2 After briefly (less than one second) pressing the Feed button twice, hold it down for at least one second, to print the R/E information.

After information printing, the Mode selection guidance is printed again.

3 To finish, turn off the power, or select "Exit and Reboot Printer".

Software Setting Mode (Customize Value Settings)

Set the printer's memory switches and customized values.

- Print density
- Auto reduction of amount of paper to use
- Enabling/disabling paper autocutting at cover close
- Paper width setting
- Auto replacement of font
- Print speed
- Command execution (offline)
- Specification for the top margin by backfeed
- Optional external buzzer control
- Interface setting
 - Communication conditions using a serial interface
 - Communication conditions using a USB interface
 - Interface switch waiting time
 - Main connection interface
- Power supply capacity
- Automatic line feed
- Select paper sensor(s) to output paper-end signals
- ERROR signal when an error occurs
- Thai Character Composition
- Character code table defaults
- International character defaults

NOTE

For details on the memory switches and customized values, see ["Software Settings" on page 62](#).

Follow the steps below.

- 1 After running a self-test, hold down the Feed button for at least one second to enter the Mode selection.**
The Mode selection guidance is printed, and the Paper LED flashes.
- 2 Briefly press the Feed button three times (less than one second), hold it down for at least one second to enter the Software settings mode (Customized value setting).**
The Software setting mode guidance is printed, and the Paper LED flashes.

Customize Value Settings

Modes

- 0: Exit
- 1: Print Current Settings
- 2: Print Density
- 3: Print Speed
- 4: Automatic Paper Reduction
- 5: Auto Paper Feed&Cut at cover close
- 6: Paper Width
- 7: Top Margin
- 8: Character/Font Settings
- 9: Interface Selection
- 10: Interface Settings
- 11: Intelligent Settings
- 12: Command Execution (Offline)
- 13: Power Supply Output
- 14: Other Settings

Select Modes by executing following procedure.

- step 1. Press the Feed button less than 1 second as many times as the selected mode number.
- step 2. Press Feed button for 1 second or more.

3 After briefly pressing the Feed button (less than one second) for the number of times shown in the print result, hold down the button for more than one second to select the setting items.

The setting selected as the setting item, the current settings and default settings are printed.

Depending on the setting item, you may need to continue selecting the setting item before the settings are printed.

For details on setting items, see "[Software Settings](#)" on page 62.

CAUTION

When set to a value other than those in the software setting mode, the current settings are not printed.

4 Select a setting by briefly pressing the Feed button (less than one second) for the number of times applicable to the setting, and then hold down the button for more than one second to confirm your selection.

After saving the settings, the Software setting mode guidance is printed, and the Paper LED flashes.

5 To close Software setting mode, turn off the printer, or select "Exit" to return to Mode selection guidance, and then select "Exit and Reboot Printer".

NOTE

- To select 0 as the item number, hold down the Feed button until printing starts.
- If the button is pressed a number of times that is not displayed by the Setup guidance, the operation is invalid and the same guidance is printed.

Restore Default Values Mode (Restore Default Values)

In Restore default values mode, following values saved on NV Memory will be set back to default settings. When any error occurs, you can use to specify the reason.

Setting Contents	Setting Items	Restore Default Values and Delete Defined Data
Customized value	✓	✓
Memory switch	✓	✓
R/E (Receipt Enhancement) settings	✓	✓
Communication condition of USB interface	✓	✓
Communication condition of network interface	✓	✓
TM-Intelligent function settings	✓	✓
NV graphics	-	✓
NV bit image	-	✓
User-defined page	-	✓
User NV Memory	-	✓

Follow the steps below.

1 After running a self-test, hold down the Feed button for at least one second to enter the Mode selection.

The Mode selection guidance is printed, and the Paper LED flashes.

2 Briefly press the Feed button four times (less than one second), hold it down for at least one second to enter the Restore Default Values.

The guidance is printed.

**3 When only restoring the default settings:
Briefly press the Feed button once (less than one second), hold it down for at least one second. (Hold down the Feed button until the message of restore completion is printed.)**

When restoring default settings and deleting user defined data:

Briefly press the Feed button twice (less than one second), and then hold it down for at least one second. (Hold down the Feed button until the restoration complete message is printed.)

4 To finish, turn off the power.

Interface Setup Mode (Interface Setup)

Use this mode to setup the interface and other settings.

Follow the steps below.

- 1 After running a self-test, hold down the Feed button for at least one second to enter the Mode selection.**
The Mode selection guidance is printed, and the Paper LED flashes.
- 2 Briefly press the Feed button five times (less than one second), hold it down for at least one second to enter the Interface Setup mode.**
The guidance is printed.
- 3 After briefly pressing the Feed button (less than one second) for the number of times shown in the print result, hold down the button for more than one second to select the setting items.**

Initialize

Select [Wi-Fi & Ethernet Setup] and select [Initialize] to restore the communication settings to the factory default. The printer is reset and restarted.

SimpleAP mode (With OT-WL06)

In Wi-Fi model, select [Wi-Fi & Ethernet Setup] and select [SimpleAP] to start in SimpleAP mode (the same as the factory default setting). The printer is reset and restarted, and several lines starting with "SimpleAP Start" and a QR code are printed.

Select this to use Quick connection for Wi-Fi model.

NOTE

For information on the Quick connection function, see "[Simple Setup for Wireless LAN](#)" on page 26.

TM-Intelligent Settings Information Print Mode (TM-Intelligent Information)

This function allows you to print TM-Intelligent setting information currently registered in the printer.

Follow the steps below.

- 1 After running a self-test, hold down the Feed button for at least one second to enter the Mode selection.**
The Mode selection guidance is printed, and the Paper LED flashes.
- 2 Briefly press the Feed button six times (less than one second), hold it down for at least one second to print the TM-Intelligent setting information.**
After information printing, the Mode selection guidance is printed again.
- 3 To finish, turn off the power, or select “Exit and Reboot Printer”.**

Peripheral Device Information Print Mode (Peripheral Device Information)

This function allows you to print information for the device currently connected to the printer.

Customer display information

Wireless LAN unit information

Follow the steps below.

- 1 After running a self-test, hold down the Feed button for at least one second to enter the Mode selection.**
The Mode selection guidance is printed, and the Paper LED flashes.
- 2 Briefly press the Feed button seven times (less than one second), hold it down for at least one second to print the Peripheral Device Information.**
After information printing, the Mode selection guidance is printed again.
- 3 To finish, turn off the power, or select “Exit and Reboot Printer”.**

Hexadecimal Dumping Mode

In hexadecimal dumping mode, data from the host device is printed in hexadecimal numbers and characters. By comparing the print outs and the program, you can check whether or not data is being sent to the printer correctly.

NOTE

- When there are no characters that correspond to the print data, "." is printed.
- If you press the Feed button when there is less than one line of print data, one line is printed.
- During hexadecimal dumping mode, applications that check the printer status may not operate correctly. The printer only returns the status for the "Real-time transmission status" command.

Follow the steps below. Entering the hexadecimal dumping mode is also possible using the ESC/POS commands.

- 1 Open the roll paper cover.**
- 2 While pressing the Feed button, turn on the printer. (Hold down the Feed button until the Error LED turns on.)**
- 3 Close the roll paper cover.**
From this point, all data received by the printer is printed in the corresponding hexadecimal numbers and ASCII characters.

Example of printing in hexadecimal dumping mode:

```
Hexadecimal Dump
To terminate hexadecimal dump,
press FEED button three times.

1B 21 00 1B 26 02 40 40 1B 69 . ! . . & . @ . i
1B 25 01 1B 63 34 00 1B 30 31 . % . . c 4 . . 0 1
41 42 43 44 45 46 47 48 49 4A A B C D E F G H I J

*** completed ***
```

- 4 To close hexadecimal dumping mode, turn off the printer after printing is complete, or press the Feed button for three times.**

Printing a Status Sheet

Follow the steps below to check the interface settings.

NOTE

When the power LED is flashing, wait until it remains lit to start printing.

Using the Status Sheet Button

- 1 If there is a connector cover, remove the cover.**
See ["Attaching the Connector Cover" on page 47](#) for details on removing the connector cover.
- 2 Check that the printer is turned on.**
Make sure the roll paper cover is closed.
- 3 Hold down the status sheet button for at least three seconds.**
The status sheet is printed.
To let the printer back to normal mode, hold down the Feed button for at least one second.

Using the Feed button

- 1 Check that the printer is on.**
- 2 Open the roll paper cover.**
- 3 Hold down the Feed button for at least one second.**
- 4 Close the roll paper cover.**
The status sheet is printed.
To let the printer back to normal mode, hold down the Feed button for at least one second.

CAUTION

- After the status sheet is printed, only the print settings of the mainly connected interface are retained. For the mainly connected interface, see ["Printing Using Multiple Interfaces" on page 28](#).
- Ethernet and Wi-Fi status sheets are not printed while the printing communication protocol is being established. They will be printed after the connection is cut off (including being cut due to a time out).
- "(none)" is printed for the "Connected Peripheral" if no peripherals are connected to the USB downstream port connector.

NOTE

Setting menus are printed following the status sheet, and you can perform any one of the following by using the Feed button.

- Print TM-i status sheet
The intelligent function connects to the server and the connection status is printed.
- Print network connection check report
Network connection is checked and the check result report is printed. For more details, see ["Network Connection Check" on page 86](#).
- Activate SimpleAP
Activate SimpleAP to establish direct wireless connection with the printer. For more details, see ["Simple Setup for Wireless LAN" on page 26](#).

Network Connection Check

Printing a Network Connection Check Report

Print a network connection check report to check whether the printer is properly connected to a network or not.

- 1 Print the status sheet.**
"Printing a Status Sheet" on page 83
- 2 Press the Feed button briefly (less than one second) twice.**
"Network connection check report" is selected in the setting menu.
- 3 Hold down the Feed button for at least one second.**
The network connection check report is printed.

Wired LAN check report sample

Check Network Connection	FAIL
Ethernet Cable Connection	NG
IP Address Check	Unchecked
Detailed IP Setup Check	Unchecked
E-01 ethernet disconnect error	

Wireless LAN check report sample

Check Network Connection	PASS
SSID Check	PASS
Communication Mode Check	PASS
Security Mode Check	PASS
MAC Address Filtering Check	PASS
Security Key/Password Check	PASS
IP Address Check	PASS
Detailed IP Setup Check	PASS

List of Errors

Error Number	Explanation
1	Ethernet disconnect error Confirm that the network cable is connected and network devices such as hub, router, or access point are turned on.
5	Wi-Fi security error Security mode (e.g. WEP, WPA) does not match the current setting of the printer. Confirm security mode.
6	MAC Address filtered MAC address of your printer may be filtered. Check whether your wireless router has restrictions such as MAC address filtering. See the documentation of the wireless router or contact your network administrator for assistance.
8	Incorrect IP Address Incorrect IP address is assigned to the printer. Confirm IP address setup of the network device (hub, router, or access point).
9	IP Communication error Confirm the connection and network setup of the PC or other device.
10	NW setting error Confirm IP address, subnet mask, and default gateway setup.
11	Gateway setting error Setup is incomplete. Confirm default gateway setup.

Resetting the Interface Settings

Follow the steps below to restore the interface settings to the factory default.

NOTE

- You can return the interface settings to their defaults from the Interface Setup mode. See ["Interface Setup Mode \(Interface Setup\)" on page 80](#) for details on the Interface Setup mode.
- Only network settings are returned to their defaults.

- 1 Turn off the printer and close the roll paper cover.**
- 2 If the connector cover is attached, remove the cover.**
See ["Attaching the Connector Cover" on page 47](#) for details on removing the connector cover.
- 3 Hold down the status sheet button while turning on the printer.**
A message is printed indicating that resetting is being performed, and the printer restarts.

CAUTION

Hold down the status sheet button until the initialization execution message is printed.

TM-Intelligent Function

This product supports the TM-Intelligent function and provides the following functions.

- Server direct print

You can set each function in the Setup Utilities. For details on the setting method for TM-T88VII Utility (for Windows), see the TM-T88VII Utility User's Manual.

You can also download a dedicated manual and sample programs from our homepage.

Server direct print

The server direct function allows this product to acquire print data from a Web server and then print.

By including print data in a response to request from this product, the Web server application can print to this product.

The features are as follows.

- You can acquire print data from three different URLs.
- Print data is available in ePOS-Print XML format.

Regarding details on server direct printing, see the Server Direct Print User's Manual.

WebConfig

WebConfig is a setting screen that allows you to check or change the printer's network settings. It is opened and used from a Web browser. To use WebConfig, it is necessary to first set the computer's IP address to the same segment as the printer.

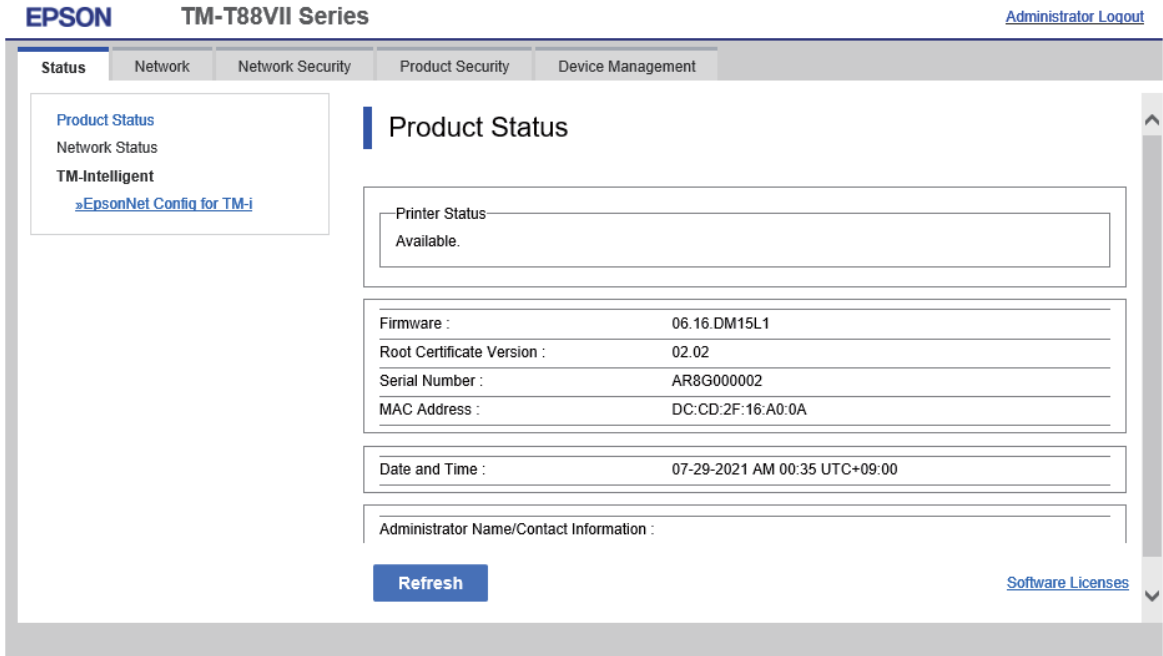

How to Start WebConfig

Start a web browser on a computer or device on the network, and then enter the printer IP address into the address bar.

When WebConfig starts up, use [Administrator login] on the top-right to display the authentication window, and then enter the password. For the default password, see "[Default administrator password for setting / Default passphrase for SimpleAP](#)" on page 133.

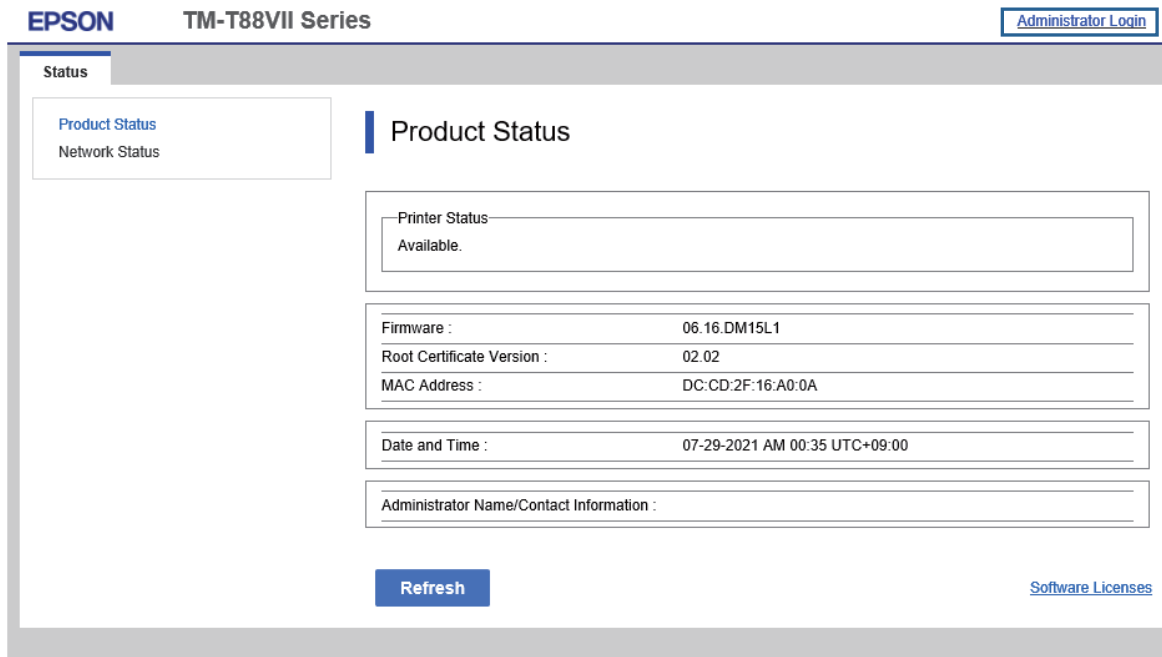

Enable the JavaScript on the browser. Because the communication with the printer uses a self-signed certificate of the printer over HTTPS, a warning message is displayed on the browser when you start WebConfig.

Communication over HTTPS

IPv4: `https://IP address of the printer`

IPv6: `https://[IP address of the printer]`

Communication over HTTP

IPv4: `http://IP address of the printer`

IPv6: `http://[IP address of the printer]`

Examples

IPv4:

`https://192.0.2.111/`

`http://192.0.2.111/`

IPv6:

`https://[2001:db8::1000:1]/`

`http://[2001:db8::1000:1]/`

Application Development Information

This chapter describes how to control the printer and gives information useful for printer application development.

Controlling the Printer

The printer supports the following command systems:

- ESC/POS
- ePOS-Print XML
- ePOS-Device XML

Users can control the printer by using the aforementioned command, or the following development kits or drivers.

- EPSON Advanced Printer Driver (APD)
- OPOS ADK
- OPOS ADK for .NET
- JavaPOS ADK
- Mac Printer Driver
- Epson TM/BA Series Thermal Printer Driver
- Epson ePOS SDK

ePOS-Print XML

ePOS-Print XML is the Epson original control command system for POS printers defined in XML. With ePOS-Print XML commands, you can print in environments where http communication is available and from OS applications. For detailed information about ePOS-Print XML, see the ePOS-Print XML User's Manual.

ePOS-Device XML

ePOS-Device XML is a command system that uses XML to define functions to control various POS peripherals (including this product printer unit) connected to this product. An application creates a request message in XML format and sends it to this product using socket communications. For detailed information about ePOS-Device XML, see the ePOS-Device XML User's Manual.

ESC/POS

ESC/POS is the Epson original printer command system for POS printers and customer display. With ESC/POS commands, you can directly control all the printer functions, but detailed knowledge of printer specifications or combination of commands is required, compared to using drivers and applications.

For detailed information about ESC/POS commands, see the ESC/POS Command Reference for TM Printers that can be accessed from the following URL:

https://support.epson.net/publist/reference_en/

Controlling the Cash Drawer

A pulse output is sent to drawer kick connector pin 2 or pin 5, and you can open the drawer.

You can also check the open/close status of the drawer by checking the signal level of the drawer kick connector pin 3.

These controls are executed by a driver or by commands.

ESC/POS Commands

Prepare the output command for the specified pulse and the status transmission command.

For details, see the ESC/POS Command Reference.

For Windows Printer Drivers (APD)

You can set so that the drawer opens at the start/end of printing or start/end of a page. For details, see the manual for drivers.

For details on control, see the manual for Status API of the driver.

OPOS (OCX Driver)

Register a cash drawer using the SetupPOS Utility, and control using the OpenDrawer method or the DirectIO function.

For details, see the "EPSON OPOS ADK MANUAL APPLICATION DEVELOPMENT GUIDE Cash Drawer" and the "UnifiedPOS Specification".

OPOS for .NET

Register a cash drawer using the SetupPOS Utility, and control using the OpenDrawer method or the DirectIO function.

For details, see the "EPSON OPOS ADK for .NET MANUAL Application Development Guide Cash Drawer (EPSON Standard)" and the "UnifiedPOS Specification".

Epson ePOS SDK

The output command for the drawer kick pulse and the status transmission command are provided in each SDK library. For details, see the user's manuals provided with each SDK.

NOTE

- Whether or not pin 2 or pin 5 operates the drawer kick connector depends on the connected cash drawer.
- You can acquire documents regarding the UnifiedPOS from the following link.
<https://www.omg.org/spec/UPOS>

Controlling the Built-in Buzzer

The software settings allow you to set the printer to emit a beep using the built-in buzzer.

Sound volume and tone cannot be changed, however, you can change the beep time by specifying pulse width.

It can be controlled using the printer driver or commands.

ESC/POS Commands

The output command for the specified pulse is used.

For details, see the ESC/POS Command Reference.

For Windows Printer Drivers (APD)

You can set so that the buzzer beeps at the start/end of printing or start/end of a page. For details, see the manual for drivers.

For API, the API for opening the drawer is used. For details, see the manual for Status API of the driver.

OPOS (OCX Driver)

Register a POS printer using the SetupPOS Utility and control using the DirectIO function.

For details, see the "EPSON OPOS ADK MANUAL APPLICATION DEVELOPMENT GUIDE POSPrinter (TM Series)".

OPOS for .NET

Register a POS printer using the SetupPOS Utility and control using the DirectIO function.

For details, see the "EPSON OPOS ADK for .NET MANUAL Application Development Guide POSPrinter (TM-T88VII)".

Epson ePOS SDK

Use the output command for the drawer kick pulse provided in each SDK library. For details, see the user's manuals provided with each SDK.

Controlling the Optional External Buzzer

You can set the optional external buzzer to buzz when an error occurs and when an automatic cut off occurs.

The buzzer can be buzzed using a driver or a command.

You can also set the timing and the beep pattern for the buzzer.

ESC/POS Command

Use the buzzer control command or the output command for the specified pulse.

For details, see the ESC/POS Command Reference.

For Windows Printer Drivers (APD)

You can set so that the buzzer beeps at the start/end of printing or start/end of a page. For details, see the manual for drivers.

For API, use the DirectIO function or the API for opening the drawer. For details, see the manual for Status API of the drivers.

OPOS (OCX Driver)

Register a POS printer using the SetupPOS Utility and control using the DirectIO function.

For details, see the "EPSON OPOS ADK MANUAL APPLICATION DEVELOPMENT GUIDE POSPrinter (TM Series)".

OPOS for .NET

Register a POS printer using the SetupPOS Utility and control using the DirectIO function.

For details, see the "EPSON OPOS ADK for .NET MANUAL Application Development Guide POSPrinter (TM-T88VII)".

Epson ePOS SDK

The command for the buzzer control is provided in each SDK library. For details, see the user's manuals provided with each SDK.



For details on setting the optional external buzzer, see ["Connecting the Optional External Buzzer" on page 45](#).

Software

The following software is provided for application development.

Development Kits

Software	Description
EPSON OPOS ADK	This OCX driver can control POS peripherals using OLE technology.*1 Because controlling POS peripherals with original commands is not required on the application side, efficient system development is possible.
EPSON OPOS ADK for .NET	The OPOS ADK for .NET is a POS industry standard printer driver compatible with Microsoft POS for .NET. It allows you to develop applications that are compatible with the UPOS (Unified POS) specification. When developing applications, use a separate development environment such as Microsoft Visual Studio .NET.
EPSON JavaPOS ADK (Windows/ Linux)	JavaPOS is the standard specification which defines an architecture and device interface (API) to access various POS devices from a Java based system. Using JavaPOS standard API allows control with Java based applications of functions inherent to each device. A flexible design with Java language and JavaPOS enables many different types of computer systems, such as stand alone or network configuration, to use a same application. You can use JavaPOS to build applications and drivers independently of platforms. This allows flexible configurations using thin clients to meet the system requirements.
Epson ePOS SDK	This is a development kit for controlling TM printers from native applications of smart devices or web applications. This includes libraries, manuals, and sample programs.
for Android	
for iOS	
for JavaScript	

*1: OLE technology developed by Microsoft divides software into part blocks. The OPOS driver is presupposed to be used with a development environment, such as Visual Basic, unlike ordinary Windows printer drivers. It is not a driver to be used for printing from commercial applications.

You can acquire documents regarding the UnifiedPOS from the following link.

<https://www.omg.org/spec/UPOS>

Drivers

Software	Description	Operating environment
EPSON Advanced Printer Driver (APD)	In addition to ordinary Windows printer driver functions, this driver has controls specific to POS. The Status API (Epson original DLL) that monitors printer status and sends ESC/POS commands is also attached to this driver.	Windows
EPSON TM Virtual Port Driver	This is a serial/parallel-USB/LAN conversion driver to make an Epson TM/BA/EU printer connected via USB or LAN accessible from a POS application through a virtual serial or parallel port. It allows you to directly control devices connected via USB or LAN with ESC/POS commands without making changes in the POS application that controls devices connected via a serial or parallel interface.	Windows
Mac Printer Driver	Mac printer driver allows you to control the printer using Common UNIX Printing System (CUPS) on Mac OS X. This is a full raster printer driver. It is able to print images, text, and vector graphics etc., that an application displays. With this driver many printer controls are possible, such as paper cut timing control, cash drawer control, printing speed control, blank line skip, and upside-down printing. It also provides API and dialogues for print setting, sample applications, and logo setting utility.	Mac OS X
TM Series Printer Driver for Linux	This driver allows you to control the printer using Common UNIX Printing System (CUPS) on GNU/Linux. This is a full raster printer driver. It is able to print images, text, and vector graphics etc., that an application displays.	GNU/Linux

Utilities

Software	Description	Operating environment
TM-T88VII Utility	A utility for checking and changing various printer settings. Use this utility to: <ul style="list-style-type: none"> • Check the current settings • Test operation • Store logos • Set paper saving • Set printing control • Set communication interfaces • Set the network • Set the intelligent function • Save/restore settings 	Windows
Epson TM Utility	A utility that is available on the App Store or Google Play. Use this to perform wireless connection setup and change settings on the printer from iOS and Android devices. This utility also comes with the following functions: <ul style="list-style-type: none"> • Sample receipt printing • Customized receipt printing • Printer status display • Quick pairing by NFC/QR code • Easy print by NFC/QR code • Firmware update 	iOS, Android

Epson Deployment Tool	Use to make network and printer settings simultaneously. Allows you to make settings efficiently at the time of introducing TM printers for the first time, or when configuring multiple TM printers at the same time.	Windows
Epson Monitoring Tool	Use to check a list of status for the Epson printers connected to the network. You can also update certificates for multiple printers used for WPA2-Enterprise in a batch.	Windows
TM-T88VII Printer Model Setting Utility	This tool allows you to change the model name for the TM-T88VII to TM-T88VI or TM-T88V.	Windows
BmpToRaster	You can convert BMP image files to multi tone or black and white print command data.	Windows
TM-T88VII Firmware Updater	This tool allows you to update the firmware for the TM-T88VII.	Windows

Others

Manual	Description
ePOS-Print XML User's Manual	Describes ePOS-Print XML statements. This manual comes with sample programs.
ePOS-Device XML User's Manual	Describes ePOS-Device XML statements. This manual comes with sample programs.
Web Config Reference Guide	Describes items that can be configured in WebConfig.

Download

You can obtain software and manuals from one of the following URLs.

For customers in North America, go to the following web site and follow the on-screen instructions.

<https://www.epson.com/support/>

For customers in other countries and regions, go to the following web site:

<https://epson.sn>

Notes on Printing Barcodes and Two-dimensional Symbols

- The user must set the quiet zone, depending on the barcode standards.
- When printing PDF417 (two-dimensional symbols), the following are recommended:
 - Module height: 3 to 5 times the module width
 - Vertical size of the symbol: approximately 5 mm {0.20"} or more
- The recognition rate of ladder barcodes and two-dimensional symbols may vary depending on widths of the modules, print density, environmental temperature, type of paper, and characteristics of the reader. Therefore, the user must check the recognition rate before setting the use conditions so that the restrictions of the reader are satisfied.
- Reading quality of barcodes and two-dimensional symbols in graphics multiple tone printing is not guaranteed.
- When printing ladder barcodes or two-dimensional symbols with graphics printing, set the print speed to speed level 4.

Automatic Certificate Update Feature

This function automates registration and periodic updating of the security certificates registered to the printer. This reduces the burden on the user of tasks such as updating.

Overview

When printing from application software that uses Epson ePOS SDK for JavaScript, if using security communication (SSL/TLS communication), security certificates must be registered on the printer and updated periodically.

Using this function automates the registration and periodic updates of security certificates so that users do not have to perform this task.

Use of this function requires the serial number of the connected printer to be entered.

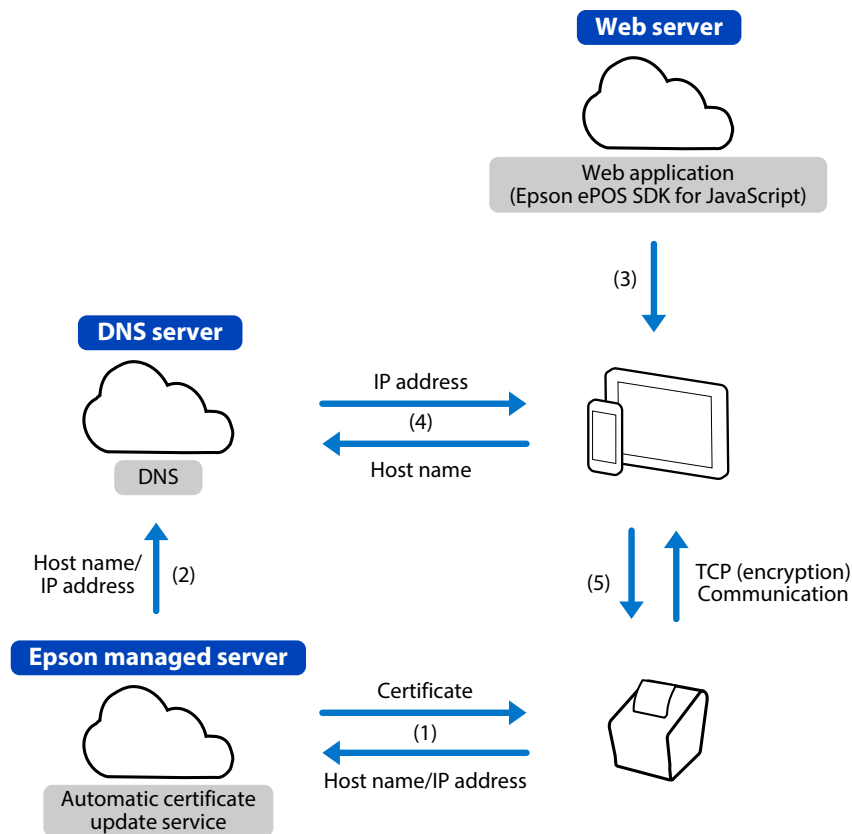

- (1) The printer downloads a certificate from the Epson-managed server and sends the host name and IP address.
- (2) The Epson server sets the host name and IP address to the DNS.
- (3) The host device uses a browser and web application to print.
- (4) The host device acquires the IP address associated with the host name from the DNS.
- (5) The host device uses TCP (encryption) communications with the printer to print.

NOTE

No personal information is acquired from the customer on the Epson-managed server side.

Use environment

- Printer firmware version: Ver.60.15 ESC/POS or later
- Application software developed using Epson ePOS SDK for JavaScript Ver.2.24.0b or later
- Both the host device and printer are connected to an Internet environment

Software required

- Epson ePOS SDK for JavaScript Ver.2.24.0b or later

One of the following setting utilities.

- TM-T88VII Utility (for Windows)
- Epson TM Utility (for iOS/Android)
- WebConfig

Refer to ["Software" on page 96](#) for information on software.

Refer to ["WebConfig" on page 89](#) for WebConfig details.

Limitations

- The security certificate is updated at printer startup and at a set time (if the printer has an update time set). If the printer is to run continuously without being turned off, be sure to set the update time.
- The printer will restart when the security certificate is updated. Since the printer cannot be used during the restart, set the update time to a time when the printer is not in use.
- Use NTP, etc., to set the printer time. This function may not operate correctly if the printer time is very incorrect.
- Depending on the proxy configuration, this function may not be usable. In this case, add the following to the browser's proxy exclusion list.
 - *.omnilinkcert.epson.biz
- If a security certificate is already registered, overwrite it.
- This function requires ISRG Root X1 in the host device certificate store.
- When saving the settings of the printer using TM-T88VII Utility or Epson TM Utility, save the security certificate as well. Otherwise, the settings may not be restored correctly.

Implementation

Programming in Epson ePOS SDK for JavaScript

For information on how to program in Epson ePOS SDK for JavaScript, refer to the user manual and samples included in Epson ePOS SDK for JavaScript.

Printer settings

- 1 Use TM-T88VII Utility, Epson TM Utility, or WebConfig to configure the following settings.**
 - Automatic Update of CA-signed certificates: Enable the setting
 - Update time: Set the time to update the certificate
 - Time Configuration: Set correct time (TimeServer or UTC, and time difference)
 - Proxy: Set up proxy as needed
- 2 Connect the host device and printer to an Internet environment.**
- 3 Print from application software developed using Epson ePOS SDK for JavaScript.**

To use this function, the host name of the printer must be designated when executing a connect method. The host name is generated by converting the serial number of the printer. A program to enter the printer's serial number is necessary on the application side. Refer to the sample programs in Epson ePOS SDK for JavaScript for information on how to convert to the host name.

Operation Check

Print the status sheet to check the status of the automatic update of CA-signed certificates.

```
Auto Cert Update : Enable
Server Access    : OK
```

Auto Cert Update / Automatic update of CA-signed certificates setting

- Disable: Certificates are not automatically updated
- Enable: Certificates are automatically updated

Server Access / Result of the last communication with the server for automatic certificate update

- OK: Successfully communicated
- Unknown: Was not communicating or is in communication
- NG (Failure): Communication failed

If "NG (Failure)" is printed, check the following.

- Is the printer connected to the Internet?
- Is the time setting of the printer correct?

Handling

This chapter describes basic handling of the printer.

Installing and Replacing Roll Paper



- **Do not open the roll paper cover during printing.**
The printer may be damaged.
- **Do not touch the manual cutter with your hands when installing or replacing the roll paper.**
Otherwise, you may be injured because the manual cutter blade is sharp.

CAUTION

- Use roll paper that meets the printer specification. For details about paper specification, see ["Paper Specifications" on page 123](#).
- Paper must not be pasted to the roll paper spool.

1 Open the roll paper cover.

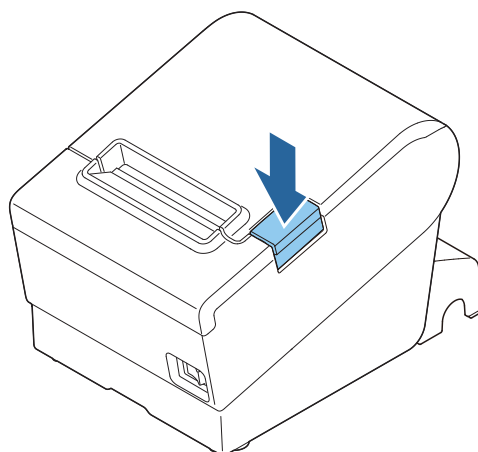

CAUTION

When the roll paper cover cannot be opened, see ["Removing Jammed Paper" on page 106](#).

2 Remove the used roll paper core, if any.

3 Install the roll paper in the correct direction.

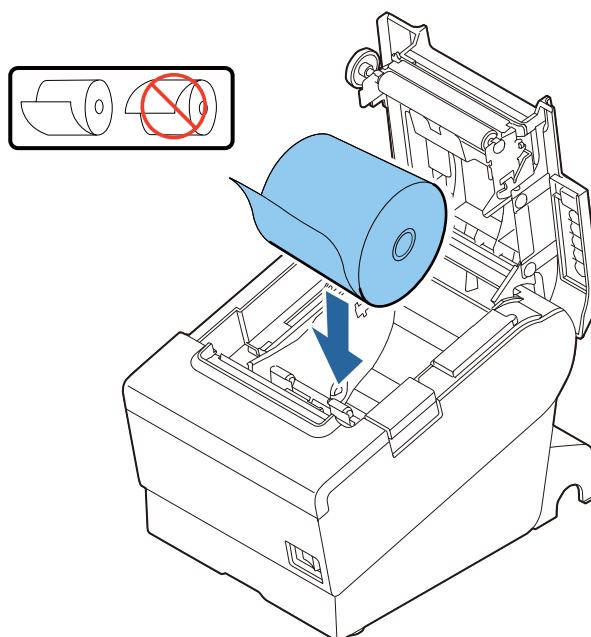
**CAUTION**

When roll paper is loaded, feed the paper for at least 20 mm.

4 Pull out some roll paper, and close the roll paper cover.

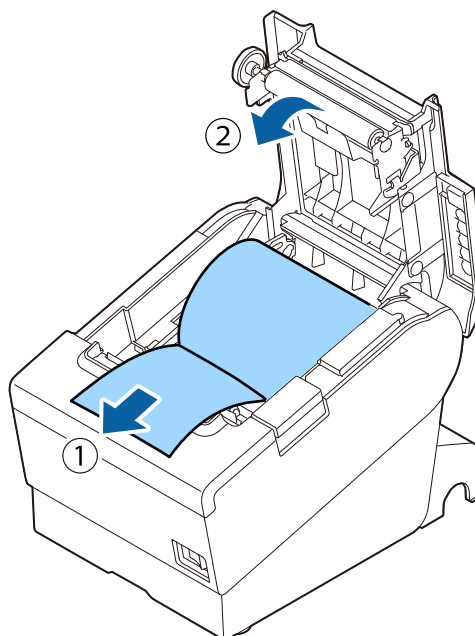

5 Tear off the paper.

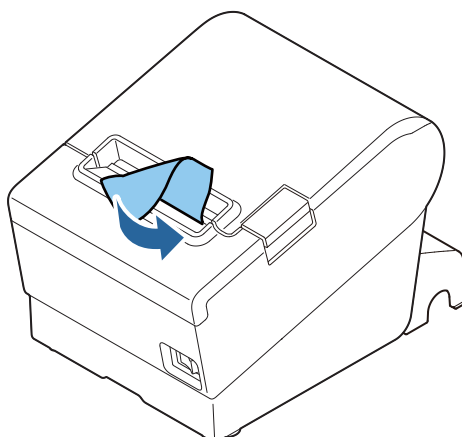

Removing Jammed Paper



Do not touch the thermal head and its surroundings. After printing, the thermal head and its surroundings can be very hot.

CAUTION

When a paper jam occurs, never pull out the paper forcibly.

Follow the steps below if the roll paper is jammed.

- 1** Turn off the printer.
- 2** Open the roll paper cover.

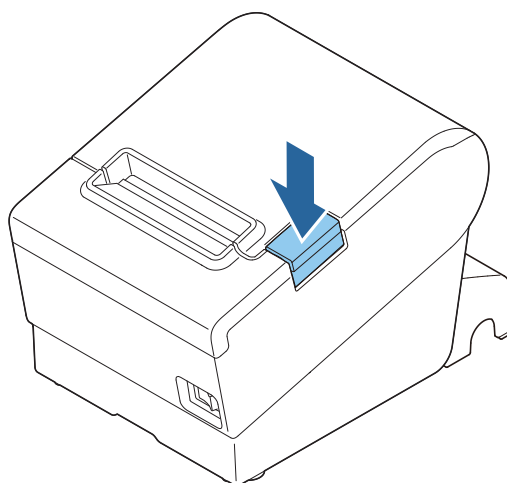

3 Remove the jammed paper.

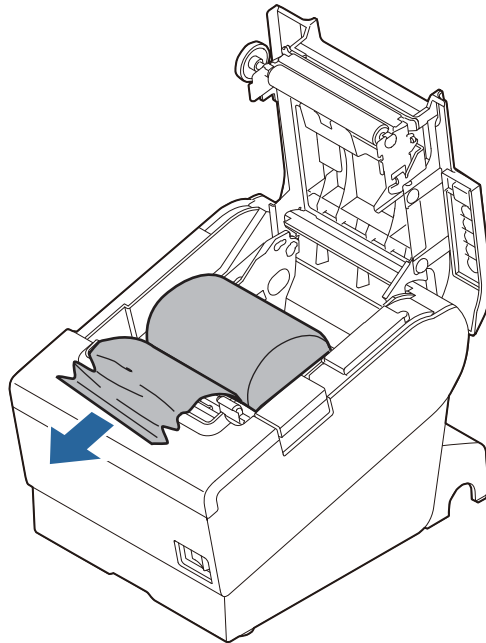

4 Close the covers.

If Roll Paper Cover does not Open

If a foreign substance has entered the autocutter or the roll paper jams, the autocutter blade cannot return to the correct position and it locks in place. In this situation, the roll paper cover does not open even if you pull the cover open lever.

Follow the steps below to return the autocutter blade to its normal position.

- 1** Turn off the printer.
- 2** Slide the cutter cover toward the front to open it.

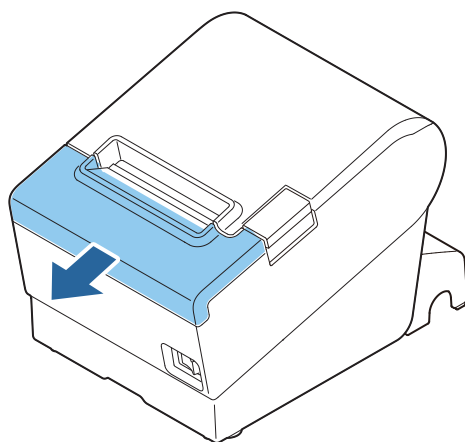

- 3** Turn the knob until you see a triangle in the opening.
This returns the cutter blade to the normal position. There is a label near the cutter to assist you.

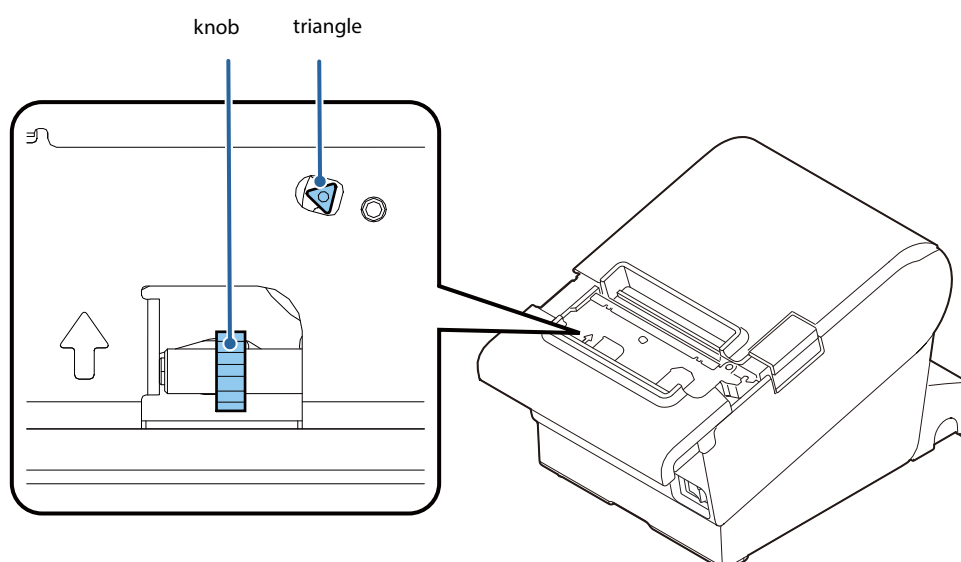

- 4** Close the cutter cover.
- 5** Open the roll paper cover and remove the jammed paper.

Cleaning the Printer

Cleaning the Printer Case

Be sure to turn off the printer, and wipe the dirt off the printer case with a dry cloth or a damp cloth. Be sure to unplug the AC cable while cleaning.

CAUTION

Never clean the product with alcohol, benzine, thinner, or other such solvents.
Doing so may damage or break the parts made of plastic and rubber.

Cleaning the Thermal Head/Platen Roller

Epson recommends cleaning the thermal head periodically (generally every 3 months) to maintain receipt print quality.

Depending on the roll paper used, paper dust may stick to the platen roller and cause an irregular paper feed. To remove the paper dust, clean the platen roller with a cotton swab moistened with water. Turn on the printer power only after the water has completely dried.

Turn off the printer, open the roll paper cover, and clean the thermal elements of the thermal head with a cotton swab moistened with an alcohol solvent (ethanol or IPA).

CAUTION

- After printing, the thermal head can be very hot. Do not touch it and let it cool before you clean it.
- Do not damage the thermal head by touching it with your fingers or any hard object.

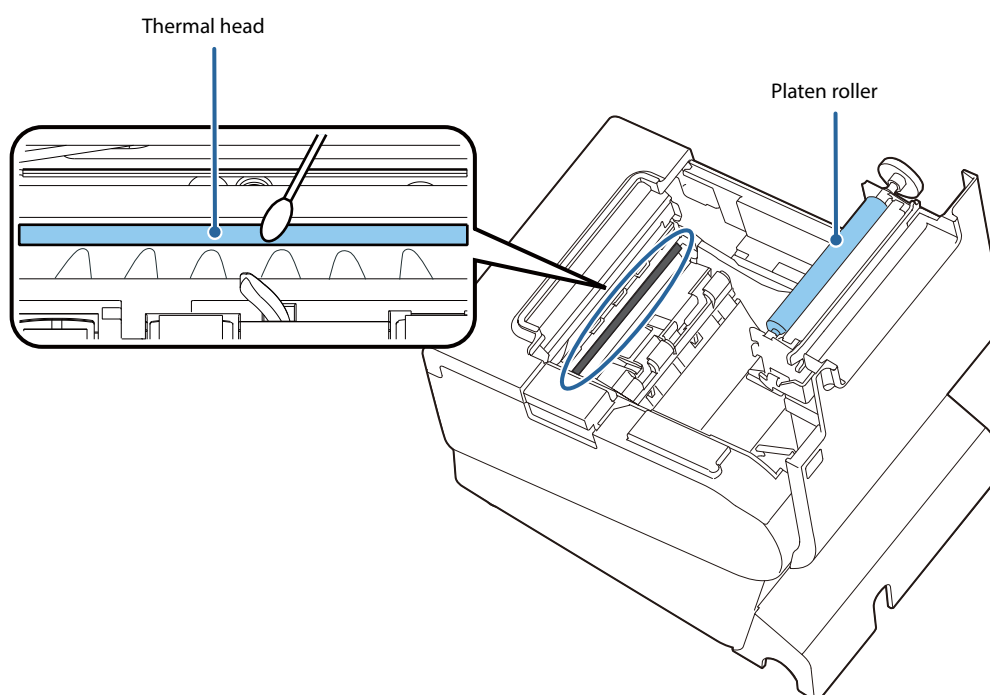

Preparing for Transport

Follow the steps below to transport the printer.

- 1** Turn off the printer.
- 2** Remove the power supply connector.
- 3** Remove the roll paper.
- 4** Pack the printer upright.

Replacement of the TM-T88VI/TM-T88V

The TM-T88VII is designed so that it can smoothly replace the TM-T88VI/TM-T88V. This chapter describes precautions for the replacement.

Compatibility

Printing

The printing and character specifications are the same as those of the TM-T88VI/TM-T88V. Without special configurations, the TM-T88VII prints the same results as the TM-T88VI/TM-T88V prints.

Print Density

The print density of TM-T88VII can be set in the same way as TM-T88VI/TM-T88V, either in the software setting mode or by DIP switches 2-3 and 2-4 (DIP switches 3 and 4 for the Fixed Interface model).

By using the same settings as TM-T88VI/TM-T88V, the same print density can be set.

Number of Head Energizing Parts

For the TM-T88VII, the default setting of the number of head energizing parts is “One-part energizing.” It does not usually need to be changed.

	TM-T88VII	TM-T88VI/TM-T88V
Number of head energizing part	<ul style="list-style-type: none"> • One-part energizing • Two-part energizing • Four-part energizing 	<ul style="list-style-type: none"> • One-part energizing • Two-part energizing • Four-part energizing

Printable Area (for 80 mm Width Paper)

The printable area (left/right margins, print start position from the autocutting position, print start position from the manual cutting position) of the TM-T88VII is the same as that of the TM-T88VI/TM-T88V.

Cutting Method

The TM-T88VII uses the partial cutting method (cutting with one point in left edge left uncut) as does the TM-T88VI/TM-T88V

Manual Paper Feed

As same with the TM-T88VI/TM-T88V, manual paper feed is not possible with the TM-T88VII.

Receive Buffer

The receive buffer of the TM-T88VII is fixed to 4 KB.

Memory Capacity

The sizes of the download buffer and NV graphics data of the TM-T88VII are the same as those of the TM-T88VI/TM-T88V.

Electrical Characteristics

The operating voltage of the TM-T88VII is $DC24\pm7\%$, the same as the TM-T88VI/TM-T88V. The current consumption differs, depending on the print duty. When you set the print speed to 500 mm/s, the amount of electricity consumed increases.

DIP Switches

The functional assignments of DIP switches for the TM-T88VII differ from the TM-T88VI/TM-T88V. See ["Setting the DIP Switches" on page 54](#) for more details.

Printer Status

The TM-T88VII goes to the same status under the same conditions as the TM-T88VI/TM-T88V. You can replace the TM-T88VI/TM-T88V with the TM-T88VII without modifying applications.

Logo Registration

The TM-T88VII can register logos in the NV memory (NVRAM) with the Setup Utilities.

Driver Compatibility

You can operate the TM-T88VII with a driver for the TM-T88VI/TM-T88V.

USB Low Power Consumption Mode

With the TM-T88VII, you can enable the USB low power consumption mode in the software setting mode.

Maintenance Counter

The TM-T88VII has a maintenance counter just as the TM-T88VI/TM-T88V has.

Buzzer

If you have set your application to sound the built-in buzzer of TM-T88VI/TM-T88V, it is possible to sound the TM-T88VII's built-in buzzer or the optional external buzzer without changing the application.

NFC

TM-T88VII/TM-T88VI has a built-in NFC tag*.

* May not be equipped depending on the printer model.

Epson TM Utility (for iOS/Android)

TM-T88VII/TM-T88VI allow you to make various settings using Epson TM Utility (for iOS/Android) which runs on an iOS or Android device.

Power Supply Box

The optional power supply box (OT-BX88VII) is available to be attached under the TM-T88VII to hold the power unit.

Overall Dimensions

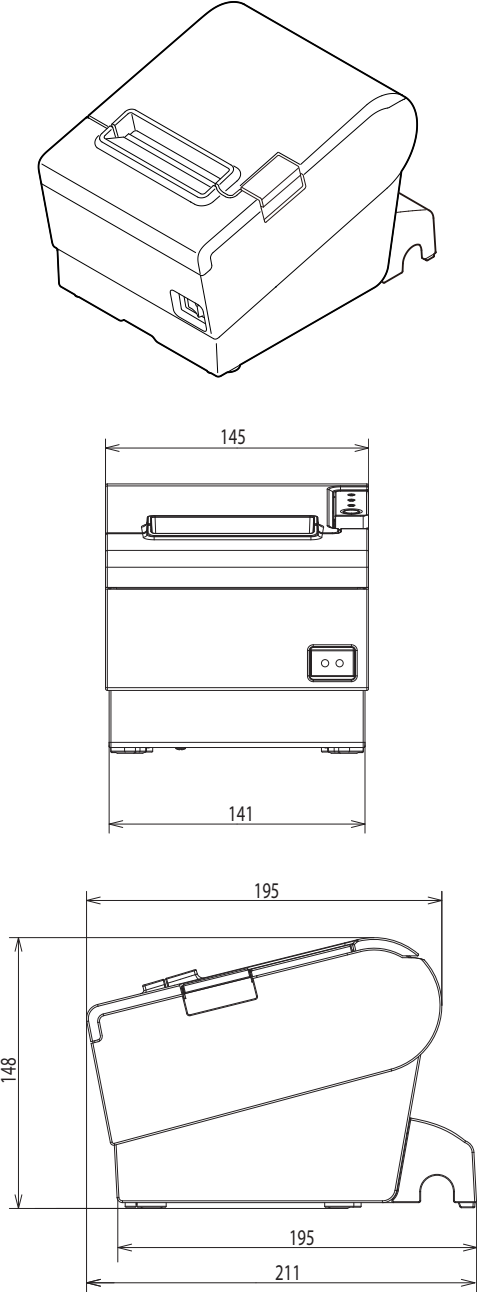
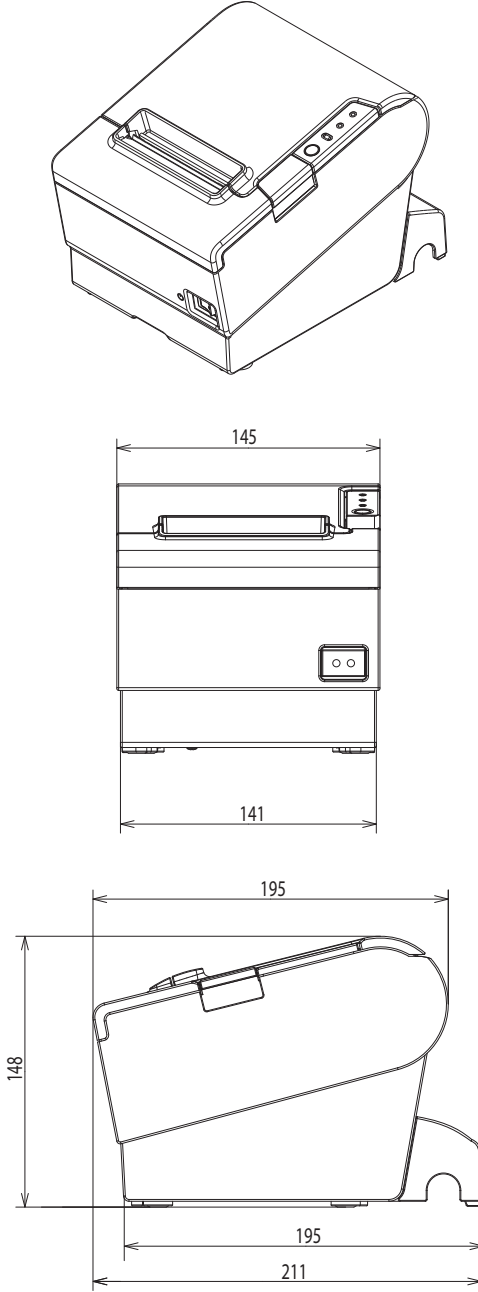
<p>TM-T88VII W:145 × D:195 × H:148 mm Approximately 1.7 kg {W:5.71" × D:7.68" × H:5.83" Approximately 3.75 lb}</p>	<p>TM-T88VI/TM-T88V (The illustrations are of TM-T88VI) W:145 × D:195 × H:148 mm Approximately 1.6 kg {W:5.71" × D:7.68" × H:5.83" Approximately 3.53 lb}</p>
	

Additional Functions and Functional Improvements

Print Speed

The default printing speed for the TM-T88VII may vary depending on the specification.

	TM-T88VII	TM-T88VI	TM-T88V
Default	400 ~ 450 mm/s	200 ~ 350 mm/s	300 mm/s
Maximum print speed	500 mm/s	350 mm/s	300 mm/s
Print speed setting (Customized value)	Level 1 to 17	Level 1 to 14	Level 1 to 13

* The values are those when the paper width is set to 80 mm. When it is set to 58 mm, the maximum is 450 mm/s {17.7"/s}.

CAUTION

Depending on print conditions such as print duty, print head temperature, and data transmission speed, print speed is automatically adjusted.

Interface

In addition to UIB, the printer is equipped with a standard USB interface and a wired LAN interface. You can perform printing using numerous interfaces.

SimpleAP Function

The TM-T88VII comes with a mode (SimpleAP) that allows the printer to connect directly when using an optional wireless LAN unit without having to use a wireless LAN access point.

Noise

TM-T88VII	TM-T88VI	TM-T88V
52 dB	55 dB	55 dB

LED Indicator

The TM-T88VII is equipped with a Wi-Fi LED and an Ethernet LED. Each LED turns on or flashes to indicate Wi-Fi or Ethernet connection status respectively.

Appendix

Product Specifications

Printing method	Thermal line printing	
Cutting method	Partial cut (cutting with one point in left edge left uncut)	
Roll paper (single-ply) width	80 mm width paper printing: 79.5±0.5 mm (3.13±0.02") 58 mm width paper printing: 57.5±0.5 mm (2.26±0.02")	
Interfaces* ¹	USB	USB 2.0 Full-speed (12 Mbps)
	Wired LAN	10BASE-T/100BASE-TX
	Serial	RS-232
	Wireless LAN	Connects an optional Wireless LAN unit to the USB connector.
	Parallel	IEEE1284
	USB Plus Power	Full-speed (12 Mbps)
Buffers	Receive buffer	4 KB
	Downloaded buffer	12 KB (both for user-defined characters and downloaded images)
	NV graphics data	384 KB
Barcode/two-dimensional symbol/ composite symbol printing	UPC-A, UPC-E, JAN8 / EAN 8, JAN13 / EAN13, Code39, Code93, Code128, ITF, CODABAR(NW-7), GS1-128, GS1 DataBar, PDF417, QR code, Maxi Code, Data Matrix, Aztec Code, Two-dimensional GS1 DataBar, Composite Symbology	
Cash drawer function	2 drives	
Supplied voltage	DC 24 V ±7%	
AC power consumption* ²	Operating	27.9 W (Serial/Parallel/Powered USB model) 26.4 W (Fixed Interface model)
	Standby	Approx. 1.4 W
Life* ³	Mechanism	20 million lines
	Thermal head	200 km (when using the specified original paper types (PD160R, TF50KS-EY, or KT55FA))
	Autocutter	3 million cuts (when using the specified original paper types (PD160R, TF50KS-EY, or KT55FA), at normal temperature and normal humidity)
MTBF* ⁴	360,000 hours	
MCBF* ⁵	70 million lines	
Temperature/humidity	Operating: 5 to 45°C {41 to 113°F}, 10 to 90% RH Storage: -10 to 50°C {14 to 122°F}, 10 to 90% RH	
Overall dimensions	145 × 195 × 148 mm {5.71 × 7.68 × 5.83"} (W × D × H)	
Mass	Approx. 1.7 kg {3.75 lb} (roll paper excluded)	

*1: The built-in interfaces vary depending on the model.

*2: According to our operation conditions

*3: Indicates the point at which the wear-out failure period starts.

*4: Indicates the mean time between failures during the random failure period.

*5: Indicates the overall mean time between failures, including wear-out and random failures, before the life is reached.

Printing Specifications

Printing method		Thermal line printing	
Dot density		180 × 180 dpi	
Printing direction		Unidirectional with friction feed (Reverse feed is not supported.)	
Printing width	Standard column mode	80 mm width paper printing: 72.2 mm (2.84"), 512 dots 58 mm width paper printing: 50.8 mm (2.0"), 360 dots	
	48 column mode	80 mm width paper printing: 67.7 mm (2.67"), 480 dots 58 mm width paper printing: 50.8 mm (2.0"), 360 dots	
Characters per line	Standard column mode	ANK font A	80 mm width paper printing: 42 58 mm width paper printing: 30
		ANK font B	80 mm width paper printing: 56 58 mm width paper printing: 40
		Kanji font A	80 mm width paper printing: 21 58 mm width paper printing: 15
		Kanji font B	80 mm width paper printing: 32 58 mm width paper printing: 22
		Special font A	80 mm width paper printing: 42 58 mm width paper printing: 30
		Special font B	80 mm width paper printing: 56 58 mm width paper printing: 40
	48 column mode	ANK font A	80 mm width paper printing: 48 58 mm width paper printing: 36
		ANK font B	80 mm width paper printing: 53 58 mm width paper printing: 40
Maximum print speed* ¹		500 mm/s* ²	
Line spacing		4.23 mm {1/6"} (Default value, programmable by command)	

dpi: dots per inch

*1: When the printer prints text (built-in fonts) with the light print density level at 24 V and 25°C {77°F}.

*2: The values are those when the paper width is set to 80 mm. When it is set to 58 mm, 450 mm/s {17.7"/s} maximum. The following conditions specify the maximum print speed regardless of the print density and paper width settings. The maximum is 100 mm/s {3.94"/s} when printing ladder barcodes or two-dimensional symbols. The maximum is 150 mm/s {5.91"/s} when printing multi-tone graphics (NV download graphics).

The maximum is 70 mm/s {2.76"/s} when printing multi-tone graphics (raster graphics).

NOTE

Print speed may be slower, depending on such items as the data transmission speed.

Character Specifications

Character set	ANK	95 alphanumeric characters		
		128 extended graphics characters x 43 pages (includes user-defined pages)		
		18 international character sets		
	Japanese	6,879 characters of JIS X 0208-1990, 845 special characters		
		11,234 characters of JIS X 0213:2004		
	Simplified Chinese	28,806 characters of GB18030-2022 (Lv.2)		
	Traditional Chinese	13,502 characters of Big5		
Korean	8,224 characters of KSC5601			
Character code ^{*1}	Japanese	ISO-2022-JP / Shift_JIS / Shift_JIS-2004		
	Simplified Chinese	GB18030-2000		
	Traditional Chinese	Big5		
	Korean	KSC5601		
	Unicode ^{*2}	UTF-8		
Character structure (W x H dots)	Standard column mode	ANK font A	12 × 24 dots (Right-side dot space: 2)	
		ANK font B	9 × 17 dots (Right-side dot space: 2)	
		Kanji font A	24 × 24 dots (Right-side dot space: 0)	
		Kanji font B	16 × 16 dots (Right-side dot space: 0)	
		Special font A	12 × 24 dots (Right-side dot space: 2)	
		Special font B	9 × 24 dots (Right-side dot space: 2)	
	48 column mode	ANK font A	10 × 24 dots (Right-side dot space: 1)	
		ANK font B	9 × 17 dots (Right-side dot space: 2)	
	Character size (W x H)	Standard column mode	ANK font A	1.41 × 3.39 mm {0.06 × 0.13"}
			ANK font B	0.99 × 2.40 mm {0.04 × 0.09"}
Kanji font A			3.39 × 3.39 mm {0.13 × 0.13"}	
Kanji font B			2.26 × 2.26 mm {0.09 × 0.09"}	
Special font A			1.41 × 3.39 mm {0.06 × 0.13"}	
Special font B			0.99 × 3.39 mm {0.04 × 0.13"}	
48 column mode		ANK font A	1.27 × 3.39 mm {0.05 × 0.13"}	
		ANK font B	0.99 × 2.40 mm {0.04 × 0.09"}	

*1: Installed character codes vary by printer model.

*2: Only the character sets installed on the printer can be printed.

Note:

1. Space between characters is not included.
2. Characters can be scaled up to 64 times as large as the standard size.

Printable Area

80 mm paper width printing

The printable area of paper with a width of 79.5 ± 0.5 mm $\{3.13 \pm 0.02\}$ " is 72.2 ± 0.2 mm $\{2.84 \pm 0.008\}$ " (512 dots), and the space on the right and left sides is approximately 3.7 mm $\{0.15\}$ ".

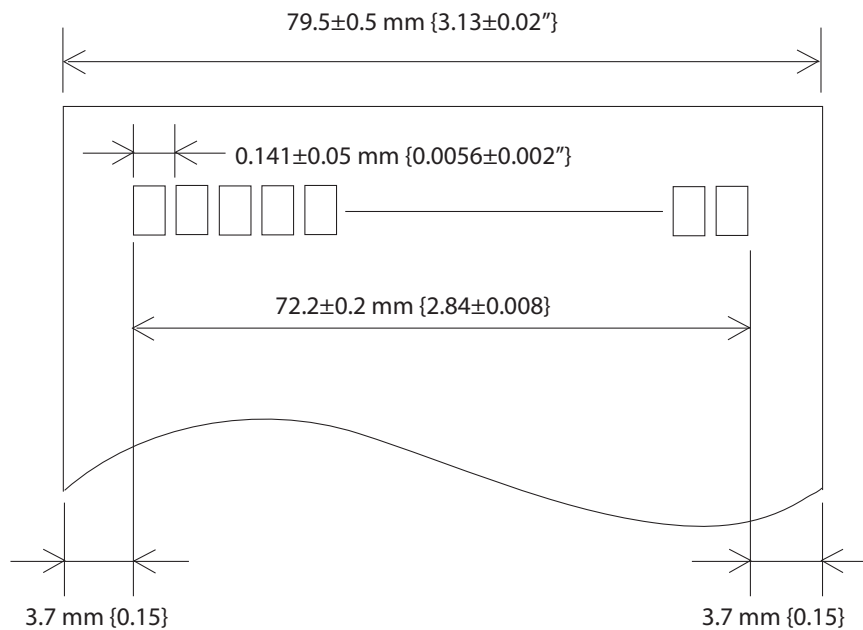

All the numeric values are typical.

CAUTION

- In 2-divided energizing, the print position within the printable area of the thermal elements for dots 1 to 256 and 257 to 512 is shifted approximately 0.07 mm $\{0.0028\}$ " in the paper feed direction as shown in the figure below.



- In 4-divided energizing, the print position within the printable area of the thermal elements for dots 1 to 128, 129 to 256, 257 to 384, and 385 to 512 is shifted approximately 0.04 mm $\{0.0016\}$ " in the paper feed direction as shown in the figure below.

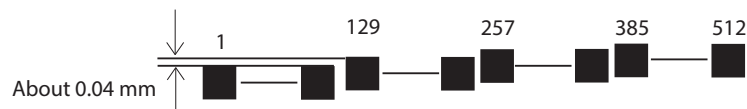

58 mm paper width printing

The printable area of paper with a width of 57.5 ± 0.5 mm { 2.26 ± 0.02 " } is 50.8 ± 0.2 mm { 2.00 ± 0.008 " } (360 dots), and the space on the left side is approximately 3.7 mm {0.15"} and the space on the right side is approximately 3.0 mm {0.12"}.

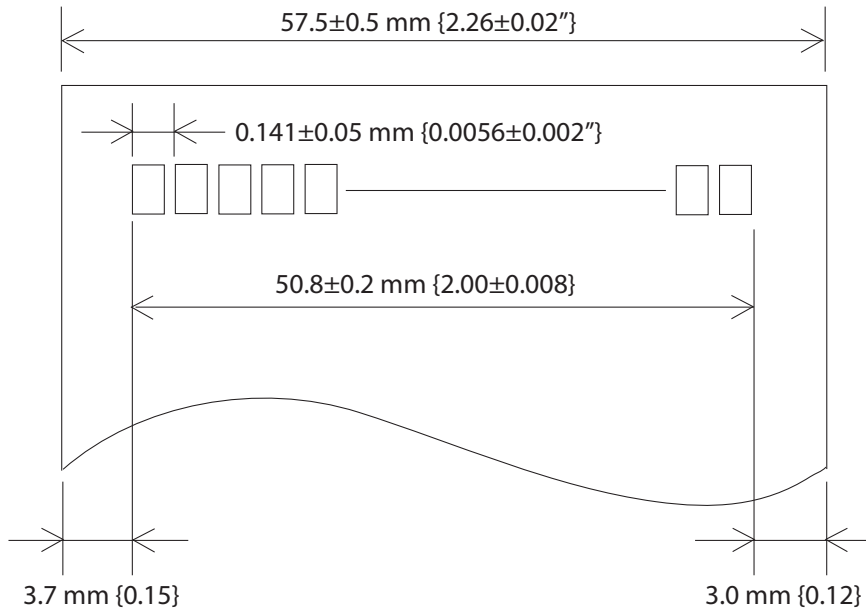

All the numeric values are typical.

CAUTION

- In 2-divided energizing, the print position within the printable area of the thermal elements for dots 1 to 256 and 257 to 360 is shifted approximately 0.07 mm {0.0028"} in the paper feed direction as shown in the figure below.



- In 4-divided energizing, the print position within the printable area of the thermal elements for dots 1 to 128, 129 to 256, and 257 to 360 is shifted approximately 0.04 mm {0.0016"} in the paper feed direction as shown in the figure below.



Printing and Cutting Positions

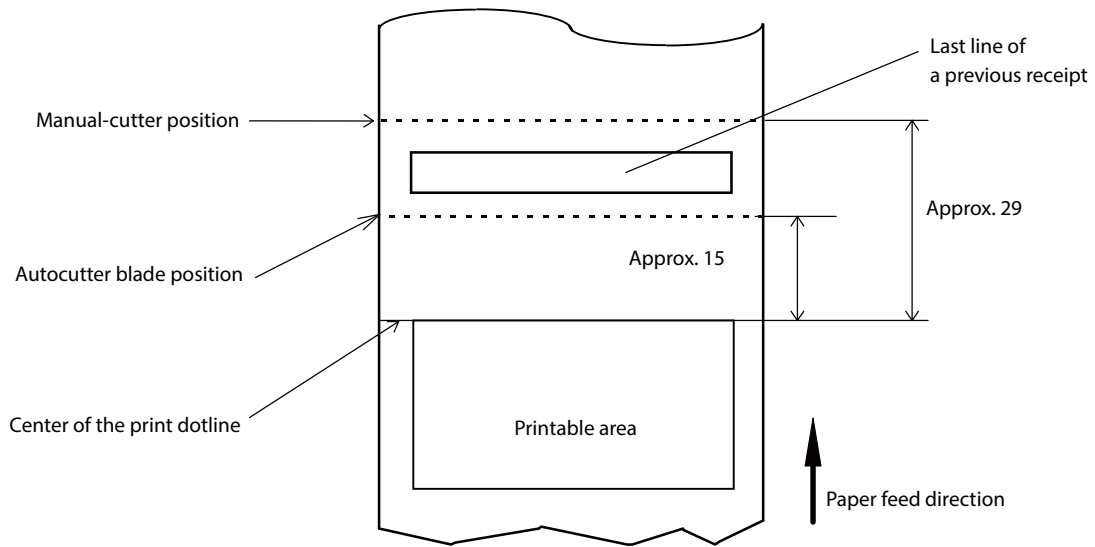

[units: mm (All the numeric values are typical.)]

CAUTION

- The values above may vary slightly as a result of paper slack or variations in the paper. Take this into account when setting the cutting position of the autocutter.
- When removing cut paper, the remaining roll paper is pulled at the uncut section and the pitch of the next print may be reduced. When printing after cutting paper for prints with no pitch reduction, feed the paper about 1 mm {16/406 inches} before printing.
- When leaving paper loaded for an extended period of time, make sure you feed about 30 mm of paper. This can prevent paper from wrinkling and causing prints to be too light.

Paper Specifications

Paper types	Specified thermal paper	
Form	Roll paper	
Size	Roll paper diameter	83 mm {3.27"} maximum
	Roll paper spool	Inside: 12 mm {0.47"}, Outside: 18 mm {0.71"}
	Roll width when taken up	80 mm width paper printing: 80+0.5/-1.0 mm 58 mm width paper printing: 58+0.5/-1.0 mm
	Paper width	80 mm width paper printing: 79.5±0.5 mm 58 mm width paper printing: 57.5±0.5 mm
	Paper thickness	Maximum of 80 µm, minimum of 48 µm
Specified original paper type	AP45KS-ND, AP50KS-ND (Jujo Thermal Oy) P5047(46), P5047(55) (Mitsubishi HiTec Paper Europe GmbH) KT55FA, KT48FA, KT55PF, KT48PF (Papierfabrik August Koehler SE) Epson Certified Media List for Thermal Receipt Printers https://support.epson.net/publist/bsredirect.php?code=M001035	

CAUTION

- Paper must not be pasted to the roll paper spool.
- The remaining amount of the roll paper when a roll paper near-end is detected differs depending on the spool type.
- Use of thermal paper with a pre-printed recording surface should be avoided. Using it can cause the thermal head to stick to the thermal paper surface during printing, and cause printing failure and other problems. The pre-printing also can result in reduced print density. Using thermal paper with a pre-printed recording surface, pre-printing should be done in accordance with the conditions (ink type, printing and other conditions) recommended by the paper manufacturer, and the thermal paper should be checked to ensure that there is no faulty printing, loss of print density, or other problems.

Electrical Characteristics

Supply voltage		DC 24 V \pm 7%
Current consumption (at 24 V, 25°C, light print density)	Standby	Approx. 0.1 A on average Up to 1 A for drawer kick driving
	Operating	Mean: Approximately 1.8 A Note: When print ratio is approximately 18% <ul style="list-style-type: none"> • Continuous printing for 30 lines (repeating 20H-7FH) <ul style="list-style-type: none"> * Font A * 42 columns * ASCII character • 5 line feeding • Autocutting

Environmental Conditions

Temperature/ Humidity	Operating	5 to 45°C {41 to 113°F}, 10 to 90% RH (See the operating temperature and humidity range below.)
	Storage (Factory packing)	-10 to 50°C {14 to 122°F}, 10 to 90% RH (except for paper)
Vibration resistance	When packed	<p>Frequency: 5 to 55 Hz</p> <p>Acceleration: Approximately 19.6 m/s² {2 G}</p> <p>Sweep: 10 minutes (half cycle)</p> <p>Time: 1 hour</p> <p>Orientation: x, y, and z</p> <p>There is no external or internal visible damage and the unit operates normally after being subjected to vibration.</p>
Shock resistance	When packed	<p>Packing: Epson standard package specifications</p> <p>Height: 60 cm {23.62"}</p> <p>Orientation: 1 corner, 3 edges, and 6 surfaces</p> <p>There is no external or internal visible damage and the unit operates normally after being dropped.</p>
	When unpacked	<p>Height: 5 cm {1.97"}</p> <p>Orientation: Lift one edge and release it (for all 4 edges)</p> <p>There is no external or internal visible damage and the unit operates normally after being dropped while not operating.</p>
Acoustic noise (operating)		<p>Approximately 52 dB (bystander position)</p> <p>Note: The values above are measured in the Epson evaluation condition.</p> <p>Acoustic noise differs depending on the paper used, printing contents, and the setting values, such as print speed or print density.</p>
Dust and drip proofness function *		<p>IPX2 equivalent</p> <p>Note: Roll paper side is excluded.</p> <p>When the rubber feet sections are installed horizontally.</p>
Altitude		Up to 3,000 m

* The value measurements are equivalent to JISC0920 (IEC60529:2001) standard. Therefore, safety standard application, and failure and breakage of the printer are not guaranteed.

External Dimensions and Mass

- Width: Approximately 145 mm {5.71"}
- Depth: Approximately 195 mm {7.68"}
- Height: Approximately 148 mm {5.83"}
- Mass: Approximately 1.7 kg {3.75 lb} (except for roll paper)

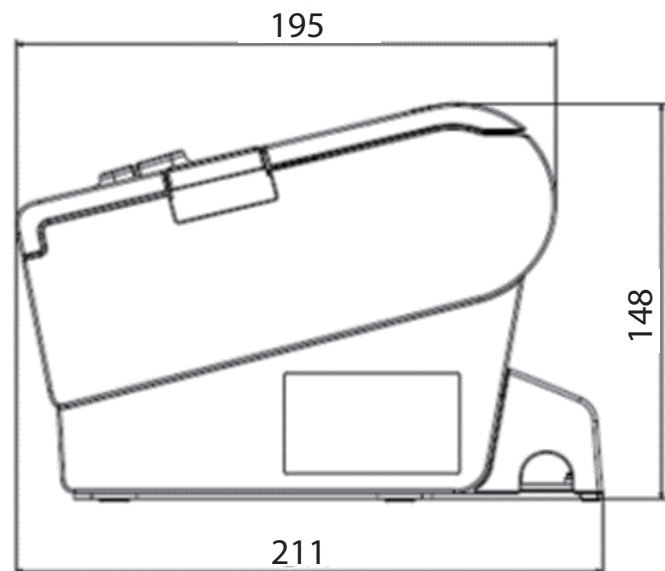
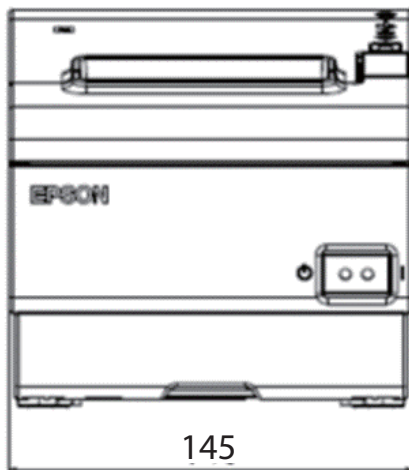
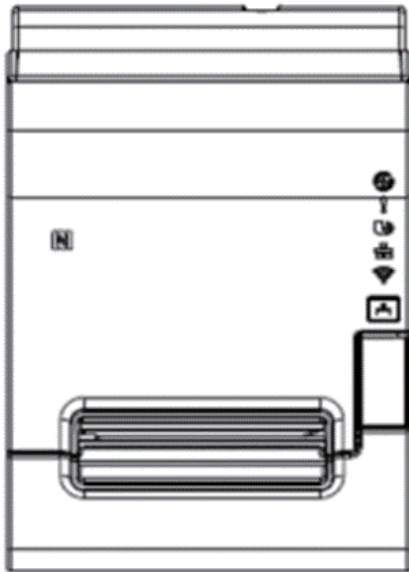

[Units: mm]

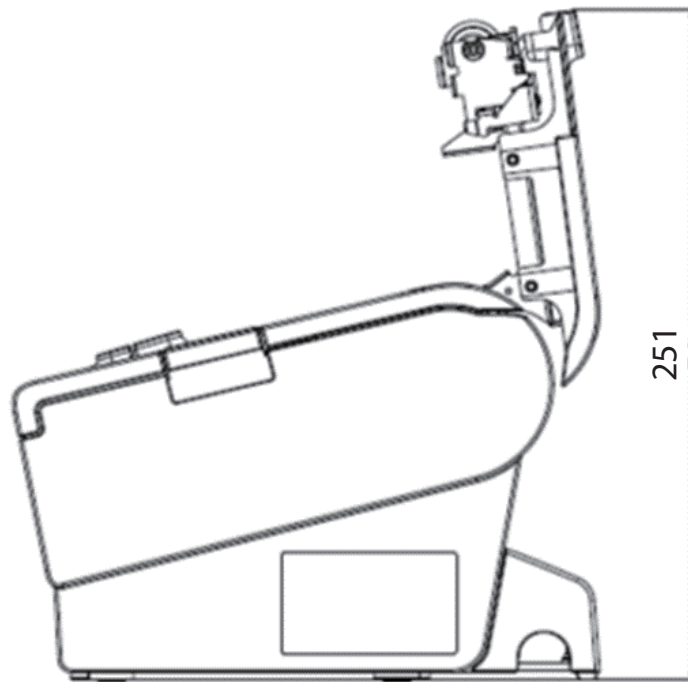

[Units: mm]

Specifications of Interfaces and Connectors

NOTE

For detailed information about parallel, see the Technical Reference Guide for the interface board.

USB Interface

USB interface connector

USB type-B connector

USB transmission specifications

USB function

Overall specifications	According to USB 2.0 specifications	
Transmission speed	USB Full-Speed (12 Mbps)	
Transmission method	USB bulk transmission method	
Power supply specifications	USB self power supply function	
Current consumed by USB bus	2 mA	
USB packet size (with full-speed connection)	USB bulk OUT (TM)	64 bytes
	USB bulk IN (TM)	64 bytes
USB device class	Both USB vendor-defined class and USB printer class are supported.	

NOTE

To set the USB device class, see ["Software Settings"](#) on page 62.

USB descriptor

		USB vendor-defined class	USB printer class
Vendor ID		04B8h	04B8h
Product ID		0202h	0E2Dh
String Descriptor	Manufacturer	EPSON	EPSON
	Product	TM-T88VII	TM-T88VII
	Serial number	Character string based on the product serial number	Character string based on the product serial number

Network Interface

For both Ethernet interface and Wi-Fi interface

Support protocols

Protocols	Usage
IP, ARP, ICMP, UDP, TCP	Basic communication protocols
LP/LPR, TCP Socket Port	Printing protocols
HTTP/HTTPS	Used in WebConfig
SNMP, ENPC	Used in setting and monitoring
DHCP, APIPA	Used in automatic setting for the IP address and so on

Network parameters

Item	Default settings
IP address	192.168.192.168*
Subnet mask	255.255.255.0*
Default gateway	0.0.0.0*
IP address acquisition	Automatic
APIPA	Disabled
IP Address Printing	Enabled
Socket Timeout	90 seconds
Community name (Read Only)	public
Community name (Read/Write)	no value
SNMP IP Trap 1	Disabled
SNMP IP Trap 2	Disabled
Communication mode	Auto negotiation
IP Filter	Disabled

* Initial value when "Acquiring the IP Address" is set to "Manual."

Printing communication protocol

- LP/LPR: Transfers printing data
- TCP Socket Port: Transfers printing data and printer status via bidirectional direct socket communication.

LP/LPR

- Max. simultaneous connections: 6
- Number of connections for which printing is available: 1 (Other users need to wait until the connection is released.)
- Time out: 90 sec. (changeable)
- Job cancel: Not available
- Banner printing: Not available

Socket communication

- Port type: TCP communication port for direct printing
- Port number: 9100
- Port communication direction: bidirectional
- Max. simultaneous connections: 6
- Number of connections for which printing is available: 1 (Other users need to wait until the connection is released.)
- Time out: 90 sec. (changeable)

For Ethernet interface

Communication specifications

10BASE-T/100BASE-TX

LED Status Indication

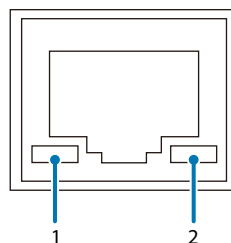

	LED	LED status	Description
1	Active/Link	Lit green	Connecting at one of the speeds
		Blinking green	Sending/receiving data
		Off	Not connected
2	Speed	Lit orange	Connecting using 100BASE-TX
		Off	Connecting using 10BASE-T

For Wi-Fi interface (With OT-WL06)

NOTE

- Countries and regions where Wi-Fi can be used are limited. Since notes are provided for each country or region, check the sheet supplied with the product.
- When using wireless LAN, make sure you disconnect the LAN cable. If a LAN cable is connected, wireless LAN is disabled.

Specification

- IEEE802.11b/g/n (2.4 GHz band) or IEEE802.11a/b/g/n (2.4 GHz or 5 GHz band) compliant Wi-Fi communication compatible.
- Infrastructure mode is supported.

Communication Standard

- IEEE802.11b (2.4 GHz)
- IEEE802.11g (2.4 GHz)
- IEEE802.11n (2.4 GHz)
- IEEE802.11a (5 GHz)
- IEEE802.11n (5 GHz)
- IEEE802.11ac (5 GHz)

Security

Security can be selected from among the following:

- WPA/WPA2-PSK
- WPA3-SAE
- WPA2/WPA3-Enterprise

Settings in SimpleAP mode (Factory default settings)

Parameter	Setting value
SSID	DIRECT-TM-T88VII-"serial number"
Passphrase	Refer to "Default administrator password for setting / Default passphrase for SimpleAP" on page 133.

* In SimpleAP mode, DHCP Server is working and assigns IP address to host automatically.

Settings in Standard Mode

Parameter	Default setting
Communication standard	Auto
Network mode	Infrastructure mode
SSID	EpsonNet
Encryption type	None
Passphrase	None

Notes on Using the Wi-Fi Model

- Keep the printer away from the devices, such as kitchen microwaves, that may cause radio wave interference.
- Use channels that are away from the frequency bands that may cause radio wave interference.
- Place shields between the printer and the devices that may cause radio wave interference.
- Select either 2.4 GHz or 5 GHz, whichever is free from radio wave interference.
- In auto channel setting for the access point, do not select a channel in which the printer may cause radio wave interference.

Notes on Wi-Fi connection

Because not all the combinations of the printer and Wireless LAN units have been checked for operation, the operation of the printer in combination with all the Wireless LAN units is not guaranteed. Be sure to carry out evaluation of the operation before use.

Notes on use

- When you initialize or change the printer settings, the printer is reset to reflect the settings. It may take about 1 minute depending on the network settings or environment. Also, your application may indicate power off during the time waiting for reset. In that case, wait for about 1 minute, and then reconnect to the printer.
- Where Wi-Fi communication is in heavy traffic, your application may falsely recognize that the communication is disconnected and indicate power off due to response delay. In that case, disable Power Save to improve the trouble.

Default administrator password for setting / Default passphrase for SimpleAP

NOTE

When using the network interface on UIB, refer to the UIB's Technical Reference Guide.

The default password and the passphrase are as follows:

Password label	Password / Passphrase
Attached to the product	Printed on the label
Not attached to the product	Product serial number (10-digit alphanumeric characters, case-sensitive)

The password label is attached to the bottom of the printer.

Example of the password label: 

The serial number is on the nameplate attached to the side of the printer. The serial number can also be found on the self-test printout and the "SimpleAP Start" sheet. On the "SimpleAP Start" sheet, the last 10 digits of the SSID are the serial number.

If the password label is lost, the default password can be checked by printing the status sheet. (If there is no password on the status sheet, the default password is a serial number.)

HHHH Network Status Sheet HHHH	
	
<General Info>	
MAC Address	XX:XX:XX:XX:XX:XX
Wi-Fi Direct MAC	XX:XX:XX:XX:XX:XX
Firmware	\$\$.\$\$.\$\$\$\$\$ (\$\$\$\$\$\$\$\$1\$\$\$\$\$/ \$\$\$\$\$\$\$)
Printer Model	\$\$\$\$\$\$\$\$\$1\$\$\$\$\$\$\$\$\$2\$ \$\$\$\$\$\$\$\$\$3\$
Device Name	\$\$\$\$\$\$\$\$\$1\$\$\$\$\$
Initial Password	\$\$\$\$\$\$\$
<Ethernet>	
Network Status	Auto(100BASE-TX, Full Duplex)
Port Type	Auto
IEEE802.3az	Enable

To improve security, it is recommended to change the administrator password from the default password.

The password can be changed using WebConfig, TM-T88VII Utility, or Epson TM Utility.

RS-232 Serial Interface

Interface board specifications (RS-232-compliant)

Item		Specifications
Data transfer method		Serial
Synchronization		Asynchronous
Handshake		Select one of the following with DIP switch 1-3: <ul style="list-style-type: none"> • DTR/DSR • XON/XOFF
Signal level	MARK	-3 to -15 V logic "1"/OFF
	SPACE	+3 to +15 V logic "0"/ON
Bit length		Select one of the following with DIP switch 1-4: <ul style="list-style-type: none"> • 7 bit • 8 bit
Transmission speed [bps: bits per second]		<ul style="list-style-type: none"> • Select one of the following with DIP switch 1-7/1-8: 4800/9600/19200/38400 bps • Select one of the following with commands: 2400/4800/9600/19200/38400/57600/115200 bps
Parity check		Select one of the following with DIP switch 1-5: <ul style="list-style-type: none"> • Yes • No
Parity selection		Select one of the following with DIP switch 1-6: <ul style="list-style-type: none"> • Even • Odd
Stop bit		1 or more bits However, the stop bit for data transfer from the printer is fixed to 1 bit.
Connector	Printer side	DSUB 25-pin (female) connector

Functions of each connector pin

Pin no.	Signal name	Signal direction	Function
1	FG	—	Frame ground
2	TXD	Output	Transmission data
3	RXD	Input	Reception data
4	RTS	Output	Equivalent to DTR signal (pin 20)

Pin no.	Signal name	Signal direction	Function
6	DSR	Input	<p>This signal indicates whether the host computer can receive data.</p> <p>SPACE indicates that the host computer can receive data. MARK indicates that the host computer cannot receive data.</p> <p>When DTR/DSR control is selected, the printer transmits data after confirming this signal (except if transmitted using some ESC/POS commands).</p> <p>When XON/XOFF control is selected, the printer does not check this signal.</p> <p>Changing DIP switch 2-7 lets this signal be used as a printer reset signal.</p> <p>When you use this signal as the printer's reset signal, the printer is reset when the signal remains MARK for a pulse width of 1 ms or more.</p>
7	SG	—	Signal ground
20	DTR	Output	<p>1) When DTR/DSR control is selected, this signal indicates whether the printer is BUSY.</p> <ul style="list-style-type: none"> • SPACE status <p>Indicates that the printer is ready to receive data.</p> <ul style="list-style-type: none"> • MARK status <p>Indicates that the printer is BUSY. Set BUSY conditions with DIP switch 2-1.</p> <p>2) When XON/XOFF control is selected, the signal indicates that the printer is properly connected and ready to receive data from the host. The signal is always SPACE, except in the following cases:</p> <ul style="list-style-type: none"> • During the period from when power is turned on to when the printer is ready to receive data. • During the self-test.
25	INT	Input	<p>Changing DIP switch 2-8 enables this signal to be used as a reset signal for the printer. The printer is reset if the signal remains at SPACE for a pulse width of 1 ms or more.</p>

XON/XOFF

When XON/XOFF control is selected, the printer transmits the XON or XOFF signals as follows. The transmission timing of XON/XOFF differs, depending on the setting of DIP switch 2-1.

Signal	Printer status	DIP switch 2-1	
		1 (ON)	0 (OFF)
XON	1) When the printer goes online after turning on the power (or reset using the interface)	Transmit	Transmit
	2) When the receive buffer is released from the buffer full state	Transmit	Transmit
	3) When the printer switches from offline to online	—	Transmit
	4) When the printer recovers from an error using some ESC/POS commands	—	Transmit
XOFF	5) When the receive buffer becomes full	Transmit	Transmit
	6) When the printer switches from online to offline	—	Transmit

Code

The hexadecimal numbers corresponding to the XON/XOFF codes are shown below.

- XON code: 11H
- XOFF code: 13H



- When the printer goes from offline to online and the receive buffer is full, XON is not transmitted.
- When the printer goes from online to offline and the receive buffer is full, XOFF is not transmitted.
- When DIP switch 1-3 is off, XON is not transmitted as long as the printer is offline, even if a receive buffer full state has been cleared.

IEEE 1284 Parallel Interface

Modes

The IEEE 1284 parallel interface supports the following two modes.

Mode	Communication direction	Other information
Compatibility mode	Host → Printer communication	Centronics-compliant
Reverse mode	Printer → Host communication	Assumes a data transfer from an asynchronous printer

Compatibility Mode

Compatibility mode allows data transmission from host to printer only: Centronics-compatible.

Specification

Data transmission	8-bit parallel
Synchronization	Externally supplied $\overline{\text{STROBE}}$ signals
Handshaking	$\overline{\text{ACK}}$ and BUSY signals
Signal levels	TTL-compatible connector
Connector	ADS-B36BLFDR176 (HONDA) or equivalent product
Reverse communication	Nibble or byte mode

Reverse Mode

The transfer of status data from the printer to the host proceeds in the nibble or byte mode.

This mode allows data transfer from an asynchronous printer under the control of the host. Data transfers in the nibble mode are made via the existing control lines in units of four bits (a nibble). In the byte mode, data transfer proceeds by making the 8-bit data lines bidirectional. Both modes fail to proceed concurrently in the compatibility mode, thereby causing half-duplex transmission.

Interface signals

Pin	Source	Compatibility Mode	Nibble Mode	Byte Mode
1	Host	Strobe	HostClk	HostClk
2	Host/Ptr	Data0 (LSB)	Data0 (LSB)	Data0 (LSB)
3	Host/Ptr	Data1	Data1	Data1
4	Host/Ptr	Data2	Data2	Data2
5	Host/Ptr	Data3	Data3	Data3
6	Host/Ptr	Data4	Data4	Data4
7	Host/Ptr	Data5	Data5	Data5
8	Host/Ptr	Data6	Data6	Data6
9	Host/Ptr	Data7 (MSB)	Data7 (MSB)	Data7 (MSB)
10	Printer	$\overline{\text{Ack}}$	PtrClk	PtrClk
11	Printer	Busy	PtrBusy/Data3,7	PtrBusy
12	Printer	Perror	AckDataReq/Data2,6	AckDataReq
13	Printer	Select	Xflag/Data1,5	Xflag
14	Host	$\overline{\text{AutoFd}}$	HostBusy k	HostBusy
15		NC	ND	ND
16		GND	GND	GND
17		FG	FG	FG
18	Printer	Logic-H	Logic-H	Logic-H
19		GND	GND	GND
20		GND	GND	GND
21		GND	GND	GND
22		GND	GND	GND
23		GND	GND	GND
24		GND	GND	GND
25		GND	GND	GND
26		GND	GND	GND
27		GND	GND	GND
28		GND	GND	GND
29		GND	GND	GND
30		GND	GND	GND

Pin	Source	Compatibility Mode	Nibble Mode	Byte Mode
31	Host	$\overline{\text{Init}}$	$\overline{\text{Init}}$	$\overline{\text{Init}}$
32	Printer	$\overline{\text{Fault}}$	$\overline{\text{DataAvail/Data0,4}}$	$\overline{\text{DataAvail}}$
33		GND	ND	ND
34	Printer	DK_STATUS	ND	ND
35	Printer	+5 V	ND	ND
36	Host	$\overline{\text{SelectIn}}$	1284-Active	1284-Active

NC: Not Connected

ND: Not Defined



- A signal name with a rule above it indicates an "L" active signal.
- Bidirectional communications cannot take place, unless all signal names for both sides correspond to each other.
- Connect all signal lines using a twisted-pair cable. Connect the return side to the signal ground level.
- Make sure the signals satisfy electrical characteristics.
- Set the leading edge and trailing edge times to 0.5 ms or less.
- Do not ignore $\overline{\text{Ack}}$ or BUSY signals during a data transfer. Ignoring such signals may result in data corruption.
- Make the interface cables as short as possible.

NFC Tag

Transmission standard	ISO14443 A
Frequency	13.56 MHz
Memory	144 byte
Transmission distance	Approximately 10 mm from the NFC installation location.

CAUTION

- The transmission distance is an estimate that depends on our experiment conditions and is not a guaranteed value.
- It varies based on the installation environment and target device.

Bluetooth Low Energy Technology Advertising

Introduction

When you connect the BT820 from Lairdtec to the USB A connector on the TM-T88VII and turn it on, the *Bluetooth* low energy technology Advertising Packet is transmitted. By default, the TM-T88VII transmits the packet according to the iBeacon Format from Apple. You can also change the data that is transmitted by following the steps in "[Changing the Bluetooth Low Energy Technology Advertising Packet](#)" on page 141.

Glossary:

Term	Description
<i>Bluetooth</i> Low Energy Technology Advertising	The name of this function.
<i>Bluetooth</i> Low Energy Technology Advertising Packet	The data sent by this function from the printer.
<i>Bluetooth</i> adapter	The BT820 from Lairdtec A USB dongle to connect to the USB Type A connector.
iBeacon	The format stipulated by Apple for <i>Bluetooth</i> low energy technology Advertising Packets When using the default settings for the TM-T88VII (<i>Bluetooth</i> adapter installed in the printer and the printer is on), the <i>Bluetooth</i> low energy technology Advertising Packet is transmitted in iBeacon format.

Dongle specifications

Manufacturer: Laird Tech

Model name: BT-820

For setting methods and settings, see the TM-T88VII Utility User's Manual.

Procedure

When turning on the TM-T88VII, the *Bluetooth* adapter connected to the USB Type A connector is enabled. If you install the *Bluetooth* adapter after turning on the printer, this is not enabled.

Bluetooth Low Energy Technology Advertising Packet Format

In the TM-T88VII, the iBeacon format is used by default for the *Bluetooth* low energy technology Advertising Packet.

The UUID for the T88VI is "fac1ba2f-61a2-4d83-9a8c-60087c232569".

The user can edit the following specifications in the iBeacon format: UUID, Major number, Minor number, and Measured Power.

Table 1 iBeacon Packet Format

Content	Data Length	Value	Description
Length of this data	1 byte	02h	
AD type	1 byte	01h	Adtype: flags
Flags	1 byte	06h	Fixed value (06h)
Length of this data	1 byte	1Ah	Fixed value (1Ah)
AD type	1 byte	FFh	Adtype: Company identifier
Company Identifier code	2 bytes	004Ch	Apple's manufacture ID
iBeacon type	1 byte	02h	Incomplete List of 16-bit service UUIDs
iBeacon length	1 byte	15h	15h=21=16+2+2+1
UUID	16 bytes	-	Default UUID = fac1ba2f-61a2-4d83-9a8c-60087c232569
Major Number	2 bytes	-	
Minor Number	2 bytes	-	
Measured Power	1 byte	05h	C5h: -59 dB

Changing the *Bluetooth* Low Energy Technology Advertising Packet

The TM-T88VII can acquire a configuration script from the printer.

You can also change settings by transmitting the configuration script to the printer.

The configuration script only supports UTF-8 encoding.

The iBeacon Format is defined in the configuration script by default for the TM-T88VII.

You can change this Packet Format to support Eddystone-UID or Eddystone-URL.

However, the T88VI only supports single Advertising Data Packets.

You can change the settings using either of the following two methods.

- Changing settings using the TM-T88VII Utility (for Windows) (see the TM-T88VII Utility User's Manual for details)
- Changing settings using an HTTP Request

The method of changing settings via an HTTP Request is explained below.

Digest authentication

You need Digest authentication to communicate with the printer.

The ID for the authentication is "epson".

For the default password, see "[Default administrator password for setting / Default passphrase for SimpleAP](#)" on [page 133](#).

Escape processing for configuration scripts

When reading/writing a configuration script for a printer, the strings (content of the configuration script) being transmitted and received uses the following escape processing. However, escape is not performed for uXXXX (hexadecimal strings) such as Japanese.

Table 2 Escape Processing

Escape	Description
\"	quotation mark
\\	reverse solidus
\b	backspace
\f	form feed
\n	line feed
\r	carriage return
\t	tab
\u002F	solidus
\u003C	<
\u003E	>
\u002B	+

Acquiring the configuration script from the printer using an HTTP request

A response for the json format is acquired using the GET method for the HTTP request.

Request

Table 3 Request Header

Request header: Content-Type: text/plain; charset=utf-8 http://(printer IP address)/webconfig/beacon.cgi?Type=(one of the following Table 4 Types)

Table 4 Types

Type	Description
(none)	If a Type is left out, the same operation is performed as when current is specified.
current	Specifies the currently enabled configuration script.
volatile	Specifies the configuration script stored in RAM.
static	Specifies the configuration script stored in ROM.
default	Specifies the default configuration script.
status	Acquires information for the <i>Bluetooth</i> adapter.

Response

Table 5 Response Header

Content-Type: application/json; charset=utf-8 Access-Control-Allow-Origin: * Access-Control-Allow-Methods: POST, GET, OPTIONS, HEADER Access-Control-Allow-Headers: Content-Type, Content-Length, Authorization X-Content-Type-Options: nosniff X-XSS-protection: 1; mode=block X-Frame-Options: deny Content-Security-Policy: default-src 'none' WWW-Authenticate: Digest realm="<IPAddr>", nonce="xx", qop="auth"

Table 6 Response

Function	GET Parameter	Results	Response
Acquires the configuration script currently enabled	Type=current Or no Type is set	Acquisition successful	200 OK
Acquires the configuration script on the RAM	Type=volatile	Acquisition successful	200 OK
		Acquisition failed (No file)	404 Not Found
Acquires the configuration script on the ROM	Type=static	Acquisition successful	200 OK
		Acquisition failed (No file)	404 Not Found
Acquires the Default configuration script	Type=default	Acquisition successful	200 OK

Function	GET Parameter	Results	Response
Acquires information from the <i>Bluetooth</i> adapter	Type=status	Acquisition successful	200 OK
		Acquisition failed (No adapter connected)	404 Not Found
Others	Type = Other than the above or A parameter except for Type exists	Type is invalid	400 Bad Request

Table 7 GET Response Body

Response Status	Response Body
200 OK	{ "message": "Success" "detail": null "description": <Encoded string for the configuration script> }
404 Not Found	"message": "Requested file not found" "detail": null "description": null }
400 Bad Request	{ "message": "Invalid Parameter" "detail": null "description": null }

Table 8 GET Response Body (Type=status)

Response Status	Response Body
200 OK The HCI Version for the <i>Bluetooth</i> adapter is 6 or higher Link	{ "message": "Success", "detail": null, "description": { "VendorID": "0a12", "ProductID": "0001", "ProductName": "CSR8510 A10", "Bluetooth LE": "Support" } }

Response Status	Response Body
200 OK The HCI Version for the <i>Bluetooth</i> adapter is 5 or lower	{ "message": "Success", "detail": null, "description": { "VendorID": "0a12", "ProductID": "0001", "ProductName": "(no name)", "Bluetooth LE": "Not support" } }
404 Not Found Adapter not connected	{ "message": "Beacon dongle not connected", "detail": null, "description": null }

Writing the configuration script to the printer

You can save a configuration script to the printer using the HTTP POST method.

You can save the configuration script to volatile or non-volatile memory.

When changing using a low frequency less than once an hour, you can save to non-volatile memory; however, when changing at a higher frequency, you need to save to volatile memory.

When the change is successful, the advertising data is changed.

Request

```
Content-Type: text/json; charset=utf-8
http://(printer IP address)/webconfig/beacon.cgi
```

See the POST parameters in Table 10 Response for the parameters.

Response

Table 9 Response Header

```
Content-Type: application/json; charset=utf-8
Access-Control-Allow-Origin: *
Access-Control-Allow-Methods: POST, GET, OPTIONS, HEADER
Access-Control-Allow-Headers: Content-Type, Content-Length, Authorization
X-Content-Type-Options: nosniff
X-XSS-protection: 1; mode=block
X-Frame-Options: deny
Content-Security-Policy: default-src 'none'
X-RateLimit-Limit: 1 (when type=static only)
X-RateLimit-Remaining: 1 or 0 (when type=static only)
X-RateLimit-Reset: 1390941626 (when type=static only)
WWW-Authenticate: Digest realm="<IPAddr>", nonce="xxxxxxxxxxxxxxxxxxxxxxxxxxxxxxxx", qop="auth"
```

Table 10 Response

Function	POST Parameters	Results	Response
Updating the configuration script in volatile memory	<pre>{ "type": "volatile", "description": "<The string for the configuration script that performed escape processing>" }</pre>	Update successful	200 OK
		Update failed When the parameter is too long	413 Request Entity Too Large
		Update failed When an error occurs when applying a new configuration script	500 Internal Server Error
Deletes the configuration script from volatile memory	<pre>{ "type": "volatile", "description": "delete" }</pre>	Deleting successful	200 OK
		Deleting failed	500 Internal Server Error
Updates the configuration script in non-volatile memory	<pre>{ "type": "static", "description": "<The string for the configuration script that performed escape processing>" }</pre>	Update successful	200 OK It has following header: X-RateLimit-Limit: 1 X-RateLimit-Remaining: 0 X-RateLimit-Reset: xx
		Update failed When the parameter is too long	413 Request Entity Too Large It has following header: X-RateLimit-Limit: 1 X-RateLimit-Remaining: 1 X-RateLimit-Reset: xx
		Update failed When an error occurs when applying a new configuration script	500 Internal Server Error It has following header: X-RateLimit-Limit: 1 X-RateLimit-Remaining: 0 X-RateLimit-Reset: xx
		Update failed When the gap between updating is more than once an hour	429 Too Many Requests It has following header: X-RateLimit-Limit: 1 X-RateLimit-Remaining: 0 X-RateLimit-Reset: xx
Deletes the configuration script from non-volatile memory	<pre>{ "type": "static", "description": "delete" }</pre>	Deleting successful	200 OK
		Deleting failed	500 Internal Server Error

Function	POST Parameters	Results	Response
Others	<ul style="list-style-type: none"> No parameters Invalid parameters Error in escape processing 	Update failed	400 Bad Request

Table 11 POST Response Body

Response Status	Body
200 OK	<pre>{ "message": "Success", "detail": null, "description": < The string for the configuration script that performed escape processing > }</pre>
400 Bad Request	<pre>{ "message": "Invalid Parameter", "detail": "****", (see Table 12) "description": null }</pre>
413 Request Entity Too Large	<pre>{ "message": "Request Entity Too Large", "detail": null, "description": null }</pre>
429 Too Many Requests	<pre>{ "message": "You sent too many requests in a given amount of time.", "detail": null, "description": null }</pre>
500 Internal Server Error	<pre>{ "message": "Failed to update settings", "detail": "****", (see Table 13) "description": null }</pre>

Table 12 400 Bad Request Details

Case	Body
The correct escape processing is not performed at the point escape processing is needed	<pre>{ "message": "Invalid Parameter", "detail": "Special characters must be escaped", "description": null }</pre>

Case	Body
An undefined Type parameter has been specified	{ "message": "Invalid Parameter", "detail": "A parameter 'type' is invalid", "description": null }
No Type specified Or an invalid parameter has been specified	{ "message": " Invalid Parameter ", "detail": "A parameter 'type' or 'description' is not specified", "description": null }
When detecting a string with invalid escape processing	{ "message": " Invalid Parameter ", "detail": "Invalid parameter is found", "description": null }

Table 13 500 Internal Server Error Details

Case	Body
Update failed	{ "message": "Failed to update settings", "detail": null, "description": null }
Deleting failed	{ "message": "Failed to delete settings", "detail": null, "description": null }
An error occurs when applying a new configuration script	{ "message": " Failed to set the settings to the beacon.", "detail": <Error code from BeaconCtrl> "description": null }

Editing the Configuration Script

In the configuration script, the settings for the module for *Bluetooth* in Linux can be written in the same way as for the Bluez hcitool, and you can customize the settings.

Make sure you include the following descriptors in the configuration script.

- Advertising stop
- Device address specifications
- Advertising parameter specifications
- Advertising start
- Advertising data specifications

Starting and stopping *Bluetooth* low energy technology Advertising

Format: cmd 0x08 0x000A n

Function: Starting and stopping transmission of the Advertising packet.

Parameter n	Length	Function
00	2 characters	Advertising stop
01	2 characters	Advertising start

NOTE

When specifying a start point, make sure you start Advertising using this command before "[Bluetooth low energy technology Advertising Packet specifications](#)" on page 150.

Device address specifications

Format: cmd 0x08 0x0005 n6 n5 n4 n3 n2 n1

Function: Specify a BD Address. Specify a value in Little Endian.

NOTE

As a Random Static Address is used in T88VI, bit7 and bit6 for n1 need to be set to 1.

Bluetooth low energy technology Advertising parameter specifications

Format: cmd 0x08 0x0006 aL aH bL bH c d e f1 f2 f3 f4 f5 f6 g h

Function: Sets a variety of parameters for the Advertising packet.

Definition	Length	Default	Description
Min advertising Interval	2 bytes	aL: a0 aH: 00	00a0h * 0.625 = 100 ms Period 00a0h is the minimum that can be specified.
Max advertising Interval	2 bytes	bL: a0 bH: 00	00a0h * 0.625 = 100 ms Period 00a0h is the minimum that can be specified.
Advertising type	1 bytes	c: 03	03h: ADD_NONCONN_IND
Own address type	1 bytes	d: 01	01h: random device address
Peer address type	1 bytes	e: 00	00h: public device address
Peer address	6 bytes	f1-f6: 00	No use
Advertising channel map	1 bytes	g: 07	07h: All channel enabled
Advertising filter policy	1 bytes	h: 02	02h: Process scan requests from all devices and only connection requests from devices that are in the White List.

See the *Bluetooth* specifications for details.

Bluetooth low energy technology Advertising Packet specifications

Format: cmd 0x08 0x0008 d1 d2 ... d32

Function: Sets the Data for the *Bluetooth* low energy technology Advertising packet.

Specify all from d1 to d32. If these are not necessary, specify 00 for each one.

Definition	Length	Default (iBeacon)	Description
Advertising data length	1 byte	d1: 1e	1eh: 30 bytes
Advertising Data	31 bytes	d2: 02 d3: 01 d4: 06 d5: 1a d6: FF d7: 4c d8: 00 d9: 02 d10: 15	02h: Length
		d11-d26: fa c1 ba 2f 61 a2 4d 83 9a 8c 60 08 7c 23 25 69	TM UUID fac1ba2f-61a2-4d83-9a8c- 60087c232569
		d27: 00 d28: Model No.	Major number The Default specifies the ID that indicates the model type using keywords shown in "Keywords" on page 151 . You can also specify a direct value.
		d29: 00 d30: IP address 4th byte	Minor number The Default specifies the 4th sector of the IP address using keywords shown in "Keywords" on page 151 . You can also specify a direct value.
		d31: C5	C5: -59 dB
		d32: 00	00h: Fixed value

Keywords

You can specify the following keywords when describing the script.

Reserve String	Length	Content	Example
\$SERIAL_ADDR	6 bytes	Address that uses 1 for the MSB2bit in the last 6 digits of the printer's serial number.	When the Serial No. is ABCD123456, the Address uses 1 for the MSB2bits for the leading 1 byte in the last 6 digits. F1:32:33:34:35:36 is generated and replaced with a string using 36 35 34 33 32 F1 sorted in Little endian.
\$RANDOM_ADDR	6 bytes	Address in which the printer generates a random 6 byte number, and 1 is for the MSB2bit of the leading 1 byte.	Generates a random 6 byte number in the printer and replaces it with a string that sorts the Address using 1 for the MSB2bits for the leading 1 byte in Little endian.
\$IPn	1 byte	Value for #n in the printer's IP address.	When the IP address is 192.168.192.168, it is replaced with the following string. IP1: c0 IP2: A8 IP3: 64 IP4: c8
\$MODEL_NO	1 byte	ID value assigned to the printer model.	02h is used for the TM-T88VII. 00: no use 01: reserve 02: TM-T88VII
\$MACn	1 byte	Value for #n in the MAC address.	Available range: \$MAC1,\$MAC2, \$MAC3, \$MAC4, \$MAC5, \$MAC6
\$BD_ADDRn	1 byte	Value for #n in the <i>Bluetooth</i> address.	Available range: \$BD_ADDR1, \$BD_ADDR2, \$BD_ADDR3, \$BD_ADDR4, \$BD_ADDR5, \$BD_ADDR6









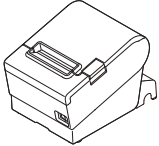

Character Code Tables

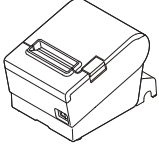
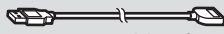
See the Character Code Tables for TM Printers that can be accessed from the following URL:

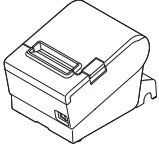
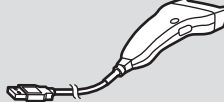
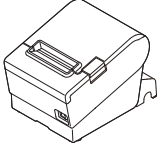
https://support.epson.net/publist/reference_en/

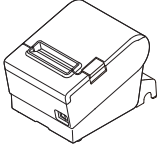
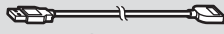
Compatibility with USB Type-A

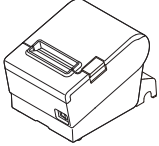
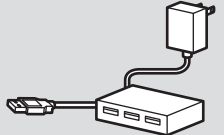
Devices can be connected to the USB Type-A connector of the TM-T88VII in the following ways.

TM-T88VII	Direct connection	Secondary connection
(a) 	 Wireless LAN unit of OT-WL06	
(b) 	 Extension cable of OT-WL06	
(c) 	 Barcode scanner	
(d) 	 Customer Display	
(e) 	 Optional extension cable OT-UL30	
(f) 	 Self powered USB hub	

NOTE

- Any USB conversion connectors and USB extension cables other than those above cannot be used.
- Barcode scanners with USB-HID interface or with CDC-ACM interface can be used.
- To use a barcode scanner, set the scanner suffix (delimiter) to CR (carriage return code). Data cannot be obtained using any other settings.